

City of Terrace Active Transportation Plan

Prepared for:
City of Terrace

Prepared by:
LEES + Associates
dplCONSULTING



LEES+Associates
Landscape Architects

dpl CONSULTING 

December 10, 2009

Contact information:

LEES + Associates

509-318 Homer St.

Vancouver, BC

V6B 2V2

T: 604-899-3806

F: 604-899-3805

elees@elac.bc.ca

dpl CONSULTING

7068 Mawhinney Cl

Burnaby, BC

V5B 4W2

T: 604-737-0043

F: 604-737-0374

dplaid@telus.net

TABLE OF CONTENTS

ACKNOWLEDGEMENTS	6
1. Introduction	7
1.1. Project Background and Objectives	7
1.2. What is Active Transportation.....	8
1.3. Methodology.....	8
1.4. Study Area.....	10
2. Inventory and Analysis	12
2.1. Introduction.....	12
2.2. Walking and Cycling Counts	12
2.3. Safety	12
2.4. Trip Potential	13
2.5. Existing Facilities	14
2.6. Opportunities and Constraints.....	19
3. Recommendations	22
3.1. Theme 1: Schools	22
3.2. Theme 2: Bridges & Crossings.....	25
3.3. Theme 3: The Benches	29
3.4. Theme 4: The Downtown	31
3.5. Theme 5: The Southside	33
3.6. Theme 6: The Horseshoe.....	34
3.7. Theme 7: Transit	35
3.8. Theme 8: Bicycle Parking.....	36
3.9. Theme 9: Maintenance.....	36
3.10. Theme 10: Education and Encouragement.....	37
3.10.1. Education Programs	38
3.10.2. Enforcement Programs.....	39
3.10.3. Involving the Community in Implementation.....	39
3.11. Changes to Related Policy Documents.....	42
3.11.1. Official Community Plan	42
4. Plan Implementation	43
4.1. Funding Opportunities	43
4.2. Priority Projects and Phasing	43

References.....46
Appendix A: Summary of Public Consultation Feedback.....47
Appendix B: Terrace Active Transportation Design Guidelines62
Appendix C: Best Practice Precedent Studies.....92
Appendix D: Signage Schedule 100
Appendix E: Funding Opportunities 102

LIST OF FIGURES

Figure 1. Bikeability assessment route9
 Figure 2. Walkability assessment route9
 Figure 3. Active transportation charrette..... 11
 Figure 4. Study area 11
 Figure 5. Wheel-bender bicycle rack 18
 Figure 6. Site analysis map.....21
 Figure 7. Way to Go! school program22
 Figure 8. 5-minute walk from schools23
 Figure 9. 10-minute walk from schools24
 Figure 10. Recommended improvements to Sande overpass.....25
 Figure 11. Sande overpass.....26
 Figure 12. Old Skeena Bridge.....27
 Figure 13. Recommended improvements to the old and new Skeena Bridges.28
 Figure 14. Proposed Kalum Street Pedestrian & Cyclist Overpass.29
 Figure 15. Recommendations to access the Bench.30
 Figure 16. Recommendations for Lanfear Drive31
 Figure 17. Proposed downtown bike rack locations.....32
 Figure 18. Custom bike rack example.32
 Figure 19. Proposed Southside recreational trail loop34
 Figure 20. Proposed pedestrian and bike boulevard - Park Avenue Connector35
 Figure 21. Transit stop with shelter, bench and posted schedules36
 Figure 22. Examples of wayfinding signage.37
 Figure 23. Examples of community cycling & walking maps.38
 Figure 24. Bicycle network map.....40
 Figure 25. Pedestrian network map41

LIST OF TABLES

Table 1. Mode of transportation to work	12
Table 2. City-wide potential for walking and cycling	13
Table 3. Existing bicycle facilities.....	14
Table 4. Existing walking facilities.....	15
Table 5. Summary of opportunities and constraints.....	20
Table 6. Action plan.	45

ACKNOWLEDGEMENTS

Funding

The Terrace Active Transportation Plan was made possible by a Community Planning grant from the Built Environment and Active Transportation (B.E.A.T.) program. B.E.A.T is a joint initiative between the BC Recreation and Parks Association and the Union of BC Municipalities and is funded through the BC Healthy Living Alliance.



Preparation

The development of this Plan was guided by input from the following individuals:

City Staff

Tara Irwin, Sustainability Coordinator

David Block, City Planner

Terrace Transportation Working Group

Kevin Kilpatrick, Ministry of Forests

Bruce Martindale, City Council / McBike Cycling Shop

Bert Husband, Terrace Standard

The Consulting Team

Erik Lees, LEES + Associates

Heidi Redman, LEES + Associates

Danelle Laidlaw, dpl CONSULTING

1. Introduction

1.1. Project Background and Objectives

Located within the Skeena River Valley, the City of Terrace is built on a series of natural flat benches. With a population of 11,320¹, Terrace has a small town atmosphere, numerous outdoor recreational opportunities and an active resident community. The City's history is tied to the Grand Trunk Railway (now CN Rail), which served as the historic backbone for development in Terrace. In the 1950's, the City became a distribution hub for surrounding communities and a trend towards automobile-focused development patterns ensued.

Constructed in 2000, the Grand Trunk Pathway is a paved multi use trail that has become the linear spine of Terrace's growing active transportation network. Running parallel to CN rail and the Yellowhead Highway (Highway 16), this trail accommodates walkers, runners, hikers, cyclists and dog walkers. While the Grand Trunk Pathway is successful, issues such as linkages between neighbourhoods, railroad crossings, topographic constraints, and the safety of children and adults remain key challenges to stimulating more active transportation trips in the city.

Objectives of the Terrace Active Transportation Plan

- Support the city's commitment to reduce greenhouse gas emissions by reducing reliance on the automobile.
- Create better active transportation connections within Terrace and to adjacent communities including Thornhill, Kitsumkalum and Kitselas.
- Increase transportation equity by ensuring cost efficient transportation choices are available to all.
- Improve physical health of residents by increasing opportunities to be physically active.
- Reduce conflicts between cyclists, pedestrian and motorists through enhanced design, signage, and education.
- Make active transportation options convenient and appealing for area residents in all seasons.
- Improve year round tourism appeal of the community and more effectively leverage funding opportunities for active transportation facilities.

A commitment by City Council to reduce greenhouse gas emissions, a recognized need to make cycling and walking more convenient and safe for the public, and a desire to increase transportation equity provide the main impetus behind the creation of the Terrace Active Transportation Plan. This Plan sets forth an approach to create better connections and increase awareness of active transportation options in the community. It also contains strategies to improve the convenience, safety and appeal of the multi modal network. In tandem with the Terrace 2050 Official Community Plan update, and the Terrace Sustainability Plan, this planning document sets the stage for the growth of an effective active transportation network in Terrace.

¹ Source: Statistics Canada 2006

1.2. What is Active Transportation

Active transportation describes all human powered forms of travel including walking, cycling, skateboarding, in-line skating and cross-country skiing. Walking and cycling are the most common and are often combined with public transit. Active transportation facilities and pedestrian and bicycle paths have many health, social, economic² and environmental benefits for a community including those shown in the text box to the right.

1.3. Methodology

This plan has been prepared based on a combination of consultant field and data evaluations, and stakeholder and community inputs. This has included field visits, walkability and bikeability assessments, interviews with staff and community partners, an online questionnaire, and two Open Houses.

Field Visits:

Field visits were conducted to assess the existing facilities. The field visits were conducted on foot, bikes and by “windshield survey” with a focus on identifying key opportunities and constraints in each neighbourhood of the study area.

Bikeability Assessment:

A Bikeability Tour was led by members of the Terrace Transportation Working Group. Key observations on the tour included the exploration of potential trail access to the Benches and identification of barriers associated with existing bridge and overpass crossings.

Benefits of Active Transportation

Health and social benefits:

- Preparing individuals and families for fluctuating and increasing fuel costs
- Creating recreational opportunities
- Enhancing community cohesion
- Promoting healthy lifestyles
- Allowing children to safely walk and bike to school
- Increasing road safety

Environmental benefits, such as:

- Reducing traffic congestion
- Reducing harmful carbon emissions

Economic benefits, such as:

- Increasing tourist appeal
- Increasing pedestrian activity in retail areas
- Increasing property values
- Reducing municipal infrastructure costs



² Québec has seen a measurable impact of bicycle tourism on its economy. In 2000, Province-wide spending by bicyclists totaled \$166 million. (Source: League of American Bicyclists, June 2009)



Figure 1. Bikeability assessment route

Walkability Assessment:

A Walkabout with Councillors and a provincial government representative was conducted in the Downtown area in order to re-acquaint participants with their community from the perspective of Active Transportation. For approximately one hour, participants walked to various locations around downtown Terrace to discuss walkability and bikeability of the area. The group looked at the “jog” intersection at Sparks, Lazelle, and Ottawa that was identified as a dangerous intersection for north and southbound cyclists. The need for increased bike parking in the Downtown became apparent with many bikes locked to street trees and other street furniture where bike racks were lacking.



Figure 2. Walkability assessment route

Staff & Stakeholder Interviews:

Staff and Stakeholders were interviewed one-on-one including discussions with representatives from the City of Terrace, Terrace RCMP, Regional District of Kitimat-Stikine, School Board/Sustainability Task Force, and the Measuring Up the North Committee. Lack of active transportation facilities, lack of signage and lack of compliance, and conflicts between cyclists/pedestrians and motor vehicles were brought forward as key issues. Interviewees also identified potential educational opportunities, and strategies to improve universal access.

Online Questionnaire:

An online survey with 10 questions was posted on the City of Terrace website for six weeks to obtain feedback on active transportation modes used by residents and the key deterrents to choosing active transportation more often. Forty people completed the survey, and identified weather and safety concerns as the top barriers to choosing multi modal travel. Walking and cycling were identified as the preferred modes of commuting using active transportation.

Active Transportation Community Charrette:

On July 30, 2009 a public charrette was held at the Terrace Sportsplex. Approximately 26 people attended. This two hour session provided an opportunity for community members to map their desired active transportation routes and identify problem areas. Participants also ranked their top priorities for active transportation improvements.

For a full summary of consultation results, see Appendix A.



Figure 3. Active Transportation Charrette, Terrace Sportsplex July 30, 2009

1.4. Study Area

For the purposes of this Plan, the study area has been divided into four neighbourhoods (Figure 4). These are:

- The Benches
- The Downtown
- The Southside
- The Horseshoe



Figure 4. Study area

These four theme areas reflect parts of the community that have similar topography, built environments, and physical barriers to active transportation. Specific recommendations for each Theme Area are outlined in section 3.0.

2. Inventory and Analysis

2.1. Introduction

This section provides an overview of current conditions for walking and cycling in Terrace. Inventory and analyses are based on field evaluations, background data review, interviews, and public comments provided during consultations.

2.2. Walking and Cycling Counts

While the City does not have bicycle count data, some data on commuting to work is captured by the Canada Census. In 2006, 13% (or 680) of employed residents in Terrace reported walking or bicycling as their primary mode of transportation to and from work. This is significantly higher than the BC average of 9%. Note that the Canada Census does not capture trips made for recreation, social purposes, or errands or trips made by those under age 16, and so it undercounts the amount of walking and bicycle trips made in the City.

Mode of transportation to work	Terrace, City			British Columbia		
	Total	Male	Female	Total	Male	Female
Total employed labour force 15 yrs and over with a usual place of work or no fixed workplace address	5,080	2,615	2,460	1,890,055	1,000,275	889,780
Car, truck, van, as driver	3,770	1,945	1,820	1,353,790	755,115	598,675
Car, truck, van, as passenger	525	240	290	145,840	63,700	82,145
Public transit	55	25	30	195,145	81,655	113,490
Walked or bicycled	680	390	290	167,650	82,510	85,135
All other modes	50	15	35	27,620	17,295	10,330

Table 1. Mode of transportation to work
Source: Statistics Canada, 2006 Census of Population

2.3. Safety

High rates of police-reported motor vehicle incidents involving injuries to pedestrians or cyclists have been reported in Terrace³. During the public consultations, safety was rated as the biggest concern and barrier to active transportation in the Terrace area with 75% of respondents indicating it was their top issue, and 100% putting safety in the top three. As such, improving safety is one of the main goals identified for this plan. A safe pedestrian and cycling environment is essential for making active transportation an appealing mode of transportation in the City, and for preventing crashes and injuries. Improvement of existing physical conditions, in conjunction with education and enforcement programs is needed to improve the safety of pedestrians and cyclists in Terrace.

³ Terrace RCMP Detachment, Personal Communication, 2009.

2.4. Trip Potential

Terrace, like many small communities in BC, has strong potential for increasing the amount of walking, cycling and other active transportation modes used by residents. The east-west distance across the City (along Highway 16 from Kalum Street to Kitsumkalum) is approximately 4.8 km, or 20 minutes by bicycle. The north-south distance from Halliwell to Graham Avenue, crossing the Sande overpass, is approximately 4.0 km or 16 minutes by bicycles. Based on average cycling speeds, this means that most Terrace residents live within 10-15 minutes cycling distance of grocery stores, retail centres, work, school, parks, and transit connections.



City-wide potential for walking and cycling	 Walking (avg 5 km/hr)	 Cycling (avg 15 km/hr)
Kalum Street to Kitsumkalum (4.8 km)	1 hour	20 minutes
Halliwell to Graham Avenue (4.0 km)	48 minutes	16 minutes

Table 2. City-wide potential for walking and cycling

Greenhouse Gas Reduction Possibilities

At the Terrace Active Transportation Open House, 73% of respondents indicated they would walk or cycle more if there was regular snow removal.

The average person makes five (one-way) trips per day in their car. Based on an average trip distance of 4 km, if 73% of Terrace residents made one trip per day by walking or cycling, this would result in a greenhouse gas (GHG) reduction of 1320 tonnes per year¹.

^[1] Based on emissions information from Transport Canada - Key Sustainable Development Strategy 2001-2003



2.5. Existing Facilities

Existing Cycling Facilities



Striped bike lane on Eby Street



The Grand Trunk Pathway multi use trail



Recreational trails along Howe Creek

The City currently has approximately 8 km of on on-road cycling facilities and 5 km of off-road facilities (see Table 3).

Bicycle Facility Type	Km
Striped Bicycle Lane	4.9
On-road Bicycles Routes (No Marked Lane)	2.9
Multi Use Pathway	4.6
<i>Total Bicycle Network</i>	<i>12.4</i>
<i>% of Roads with a Bicycle Route</i>	<i>10%</i>

Table 3. Existing bicycle facilities

The main elements of the existing bicycle network include:

- Multi use trails along Howe Creek and the Grand Trunk Pathway;
- Striped bike lanes on Eby, Sparks, and Kalum Streets, and
- Designated (unmarked) on-road bicycle routes such as Halliwell Ave, Skeenaview Drive, and Lanfeair Drive.

The spine of the existing bicycle system is the Grand Trunk Pathway, which provides an east west connection from Kalum Lake Road/Braun Street to Eby Street. Future plans to extend the pathway west to Kitsumkalum and east to Kalum Street will provide a continuous off-road multi use spine across the city. While several streets have on-road striped (painted) bicycle lanes, none of these are connected and they end abruptly. A grade change between the road lip and the gutter pan, and inconsistent plowing of lanes in the winter are some of the main challenges

associated with the existing bike lanes. There are no signed bike routes or marked shared roadways, creating further impediments to enhancing bikeability in Terrace.

Existing Walking Facilities



Pedestrian controlled light on Sparks at Lakelse



Shade trees, Lazelle Avenue



Covered sidewalk, downtown Terrace

Terrace currently has approximately 32.6 km of separated sidewalks and 11.4 km of walkways and trails (see Table 4).

Walking Facility Type	Km
Totally Walkways and Trails	11.4
Total Separated Sidewalks	33
Total Roadways ⁴	83
<i>% of Roads with Separated Sidewalk</i>	<i>40%</i>

Table 4. Existing walking facilities

The main elements of the pedestrian network include:

- Multi use trails along Howe Creek and the Grand Trunk Pathway;
- Separated sidewalks on most streets in the Downtown and Horseshoe, and
- Recreational trails on Ferry Island.

⁴ Taken from aerial photo provided by City of Terrace. Does not include MOT facilities.

Existing Transit Facilities

The Terrace Regional Transit System is funded by BC Transit, the City of Terrace, and the Regional District of Kitimat-Stikine, based on a cost-sharing agreement. The fleet includes kneeling buses and Handy Dart shuttles, operated by Coast Mountain Bus Ltd. Currently, there are nine routes with connections to Thornhill, Queensway, Kitsumkalum, the College/Halliwell, Downtown and the Southside. Buses that currently service Terrace are equipped with bike racks on the front, so cyclists can use a combination of transit and cycling to commute. Infrequent service and low ridership have been reported at consultation sessions, and transit was identified as an ineffective alternative to vehicle travel.

BC Transit reports high ridership in Terrace. A ridership survey has not been completed which would provide concrete data on ridership levels, and seasonal variations. Opportunities to work with BC Transit to improve service in Terrace should be explored.

Public Transit and Active Transportation

Public transit is an important part of a successful active transportation network – it complements active modes by allowing both pedestrians and cyclists to complete longer trips in conjunction with transit. In addition, public transit usually involves walking to and from the transit stop and one's destination.

Seniors use transit more than any other age group - public transit use as a percentage of total trips taken increases dramatically with age. The Canadian Urban Transit Association (CUTA) forecasts that, since the riders aged 65 and over are expected to increase off-peak ridership, demand for “community bus” type services, connecting residential areas to shopping, health care facilities, and community centres will need to increase in the future (Transport Canada 2006).



Bridges and Crossings

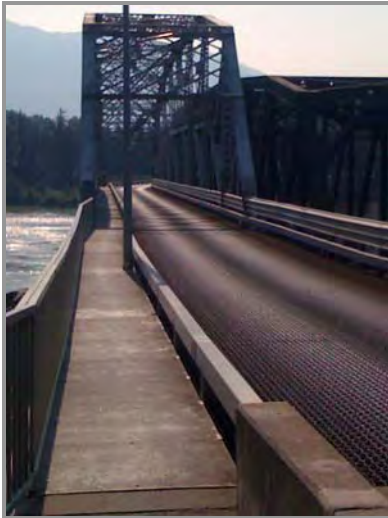

Old Skeena Bridge



Sande overpass

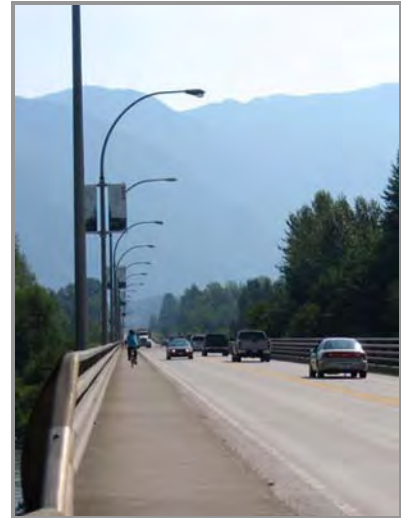

New Skeena Bridge

Other existing barriers to active transportation include bridge crossings and crossing of the railroad/ Highway 16:

- Narrow sidewalk on the Kalum River Bridge.
- Lack of a sidewalk on the south side, and lack of underpass to access the north sidewalk on the “New Skeena Bridge.”
- Narrow sidewalk and difficult approach to the heritage “Old Skeena Bridge.”
- Inadequate approaches, lack of railings and a high sidewalk on the Sande overpass.
- General lack of crossing points of the railroad and Highway 16.

Supporting Facilities



Bus shelter with amenities



Rest area with benches



Bike rack, downtown Terrace

The City's supporting facilities for active transportation include bicycle racks on buses, shelters, bike racks in commercial areas and near schools, and rest points (benches) along the Grand Trunk Pathway and in the Downtown. Some of the older bike racks are a "wheelbender" design which are considered sub-standard because they support only the wheel of the bike and not the frame.



Figure 5. Wheel-bender bicycle rack

2.6. Opportunities and Constraints

Opportunities	Reason
Riverwalk	<ul style="list-style-type: none"> • Skeena River is a desirable destination for a recreational loop trail • Can provide year round tourism appeal and link to downtown
Trail System	<ul style="list-style-type: none"> • Terrace has a robust trails system that the AT network can enhance
Schools	<ul style="list-style-type: none"> • Improving walking and cycling facilities around schools can have a major impact on increasing active travel in the City
Grand Trunk Pathway	<ul style="list-style-type: none"> • A central spine for the future city-wide AT network • The GTP has increased visibility and awareness of walking and cycling as modes of transportation
Bike Racks	<ul style="list-style-type: none"> • City is currently implementing a program to install more bike racks which provides an opportunity to develop local made-in-Terrace bike racks in conjunction with local artists/art students
Downtown	<ul style="list-style-type: none"> • Recent downtown revitalization efforts have been well received • Further pedestrianization of the downtown can have a positive impact on retail areas
Education and Encouragement Programs	<ul style="list-style-type: none"> • Programs such as the Bike Rodeo have been effective in promoting active transportation. Developing more programs and incentives, such as a Bike to Work Week Challenge, is key to improving safety and building awareness about the benefits of active travel
Constraints	Reason
Railway / Highway 16	<ul style="list-style-type: none"> • CNR and the highway bisect the community • Existing crossing points are not bicycle and pedestrian friendly
Topography	<ul style="list-style-type: none"> • Steep grades to access the Bench and Birch Bench • Lack of pedestrian and cycling facilities to safely access Benches • River erosion
Transit	<ul style="list-style-type: none"> • Transit is not well promoted and there is low ridership on many routes • Infrequent service decreases the likelihood of combining transit with other AT modes
Maintenance	<ul style="list-style-type: none"> • Lack of winter plowing of sidewalks and bicycle routes especially around schools. • Need to define ongoing and seasonal maintenance program for AT facilities
Safety Concerns	<ul style="list-style-type: none"> • Safety concerns were cited as the #2 deterrent to choosing active transportation (after weather) in the Active Transportation questionnaire • Perception of safety is a key reason for children not walking or cycling to school
Inadequate Facilities	<ul style="list-style-type: none"> • Lack of on road bicycle facilities and sidewalks especially on the Southside

	<ul style="list-style-type: none"> • No citywide wayfinding or signage strategy for active transportation is in place.
Lack of Accessible Design Features	<ul style="list-style-type: none"> • Lack of pedestrian controlled lights with audible signals. • Curb cuts are need at all crossing points; inspection and repair of serious sidewalks hazards such as missing bricks in the downtown core.

Table 5. Summary of opportunities and constraints

Figure 6 (Site Analysis Map) on the following page summarizes the active transportation inventory and documents the key active travel destinations in the City including civic destinations, commercial areas, key parks and schools.

Opportunities



Improve accessibility in the Downtown

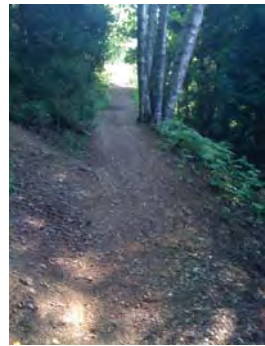

Build on the existing trail network



Improve walk- and bike-ability around schools



Provide AT access to the Skeena River

- Legend**
- Steep Slope
 - School
 - Activity Nodes
 - Poor Quality AT Connection
 - Bridge / Overpass
 - Difficult Intersection

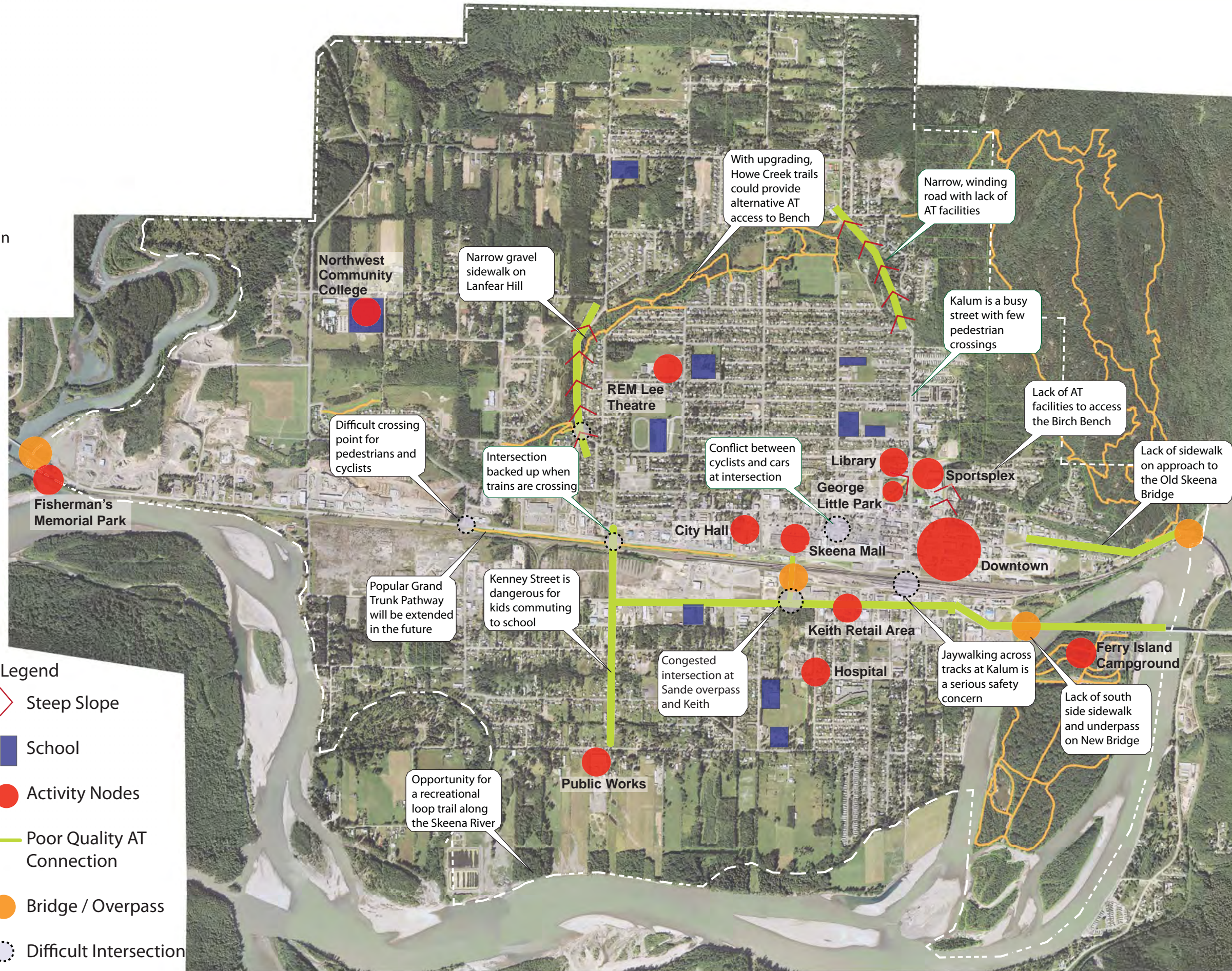

Constraints

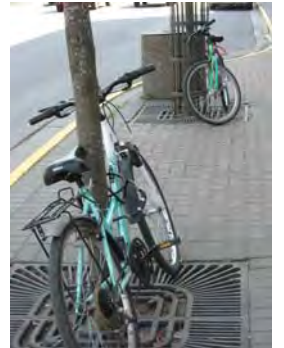

Lack of bicycle parking



Difficult bridge crossings



Lack of sidewalks around transit stops

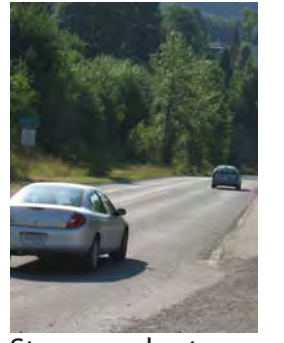

Steep grades to access the Benches

3. Recommendations

In order to meet the goals and objectives identified in this report, the following actions are recommended. The recommendations in this section are based on evaluation of existing conditions for walking and bicycling in Terrace combined with knowledge of best practices from comparable communities, Transportation Association of Canada (TAC) standards, and other relevant transportation design standards.

Refer to Appendix B Design Guidelines for more information on pedestrian and bicycle design standards referenced in the recommendations.

The top fifteen priority projects are highlighted in **bold font**.

3.1. Theme 1: Schools

There are nine elementary and high schools in Terrace plus the Northwest Community College, and a satellite campus of the University of Northern BC. At consultations, the public expressed a concern about safety as one of the primary reasons parents are reluctant to allow their children to walk or cycle to school. There is a desire to improve walkability and bikeability around schools, and to install more bike racks in visible locations on school grounds. This is important as students are more likely to walk than other members of the community. The lack of safe crossings at Highway 16 was cited as a major deterrent for youth commuting to and from the southside.

Recommendations to improve active transportation opportunities on routes to schools include the following:

1. Discourage vehicle parking within a 5-minute walk (280m) of schools for 30 minutes on either side of school opening and closing (see Figure 8).
2. **Make a priority in the sidewalk capital budget to build and upgrade sidewalks and install traffic calming within a 10-minute walk (400m) from schools** (see Figure 9).
3. Collaborate with school administrators, teachers and parent groups to implement a program to walk and bike along safe routes to schools. See ICBC's *Way to Go!* school program (www.waytogo.icbc.bc.ca). (See also Appendix C: Best Practices).



Figure 7. Way to Go! school program

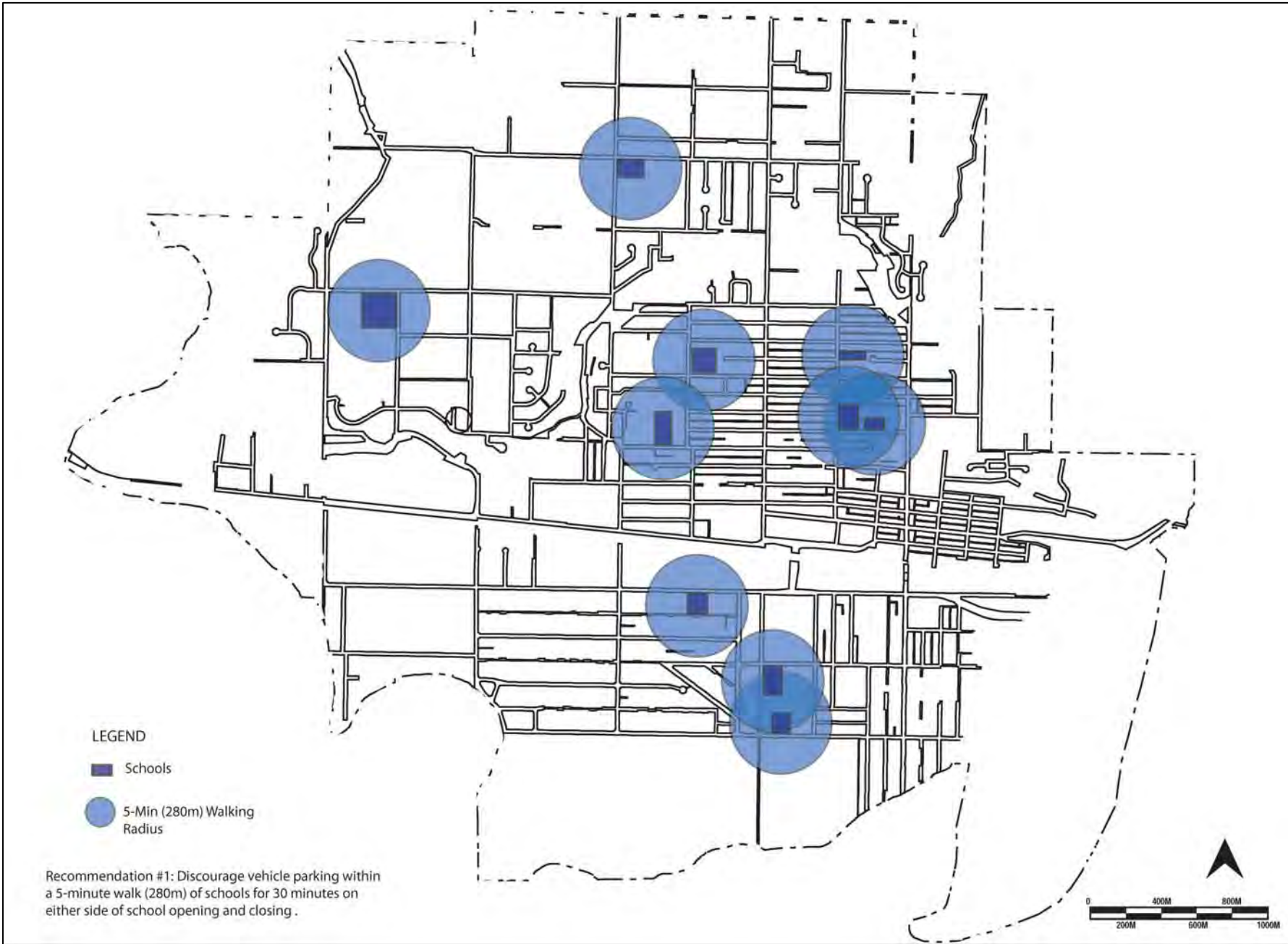

Figure 8. 5-minute walk from schools

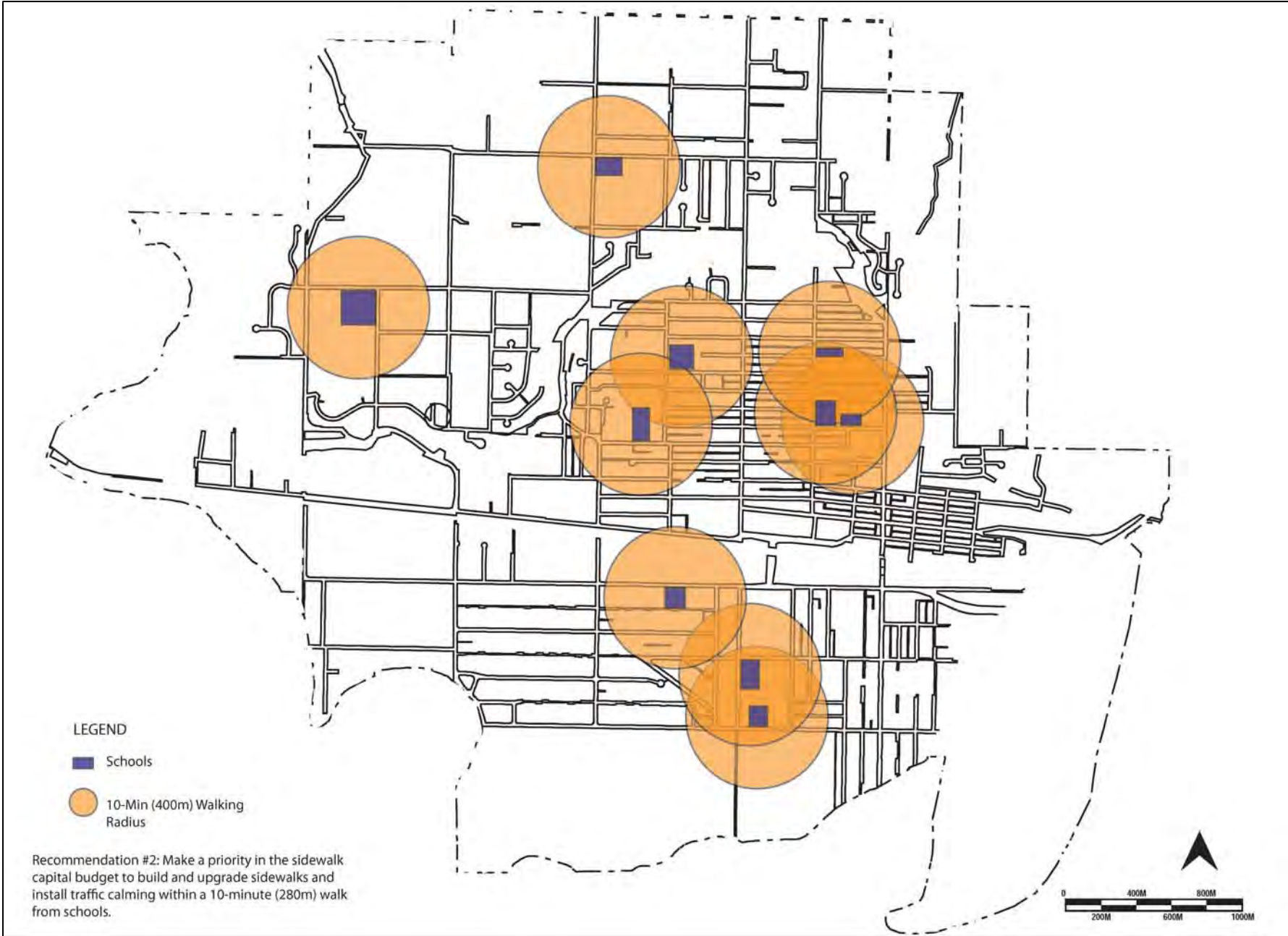

Figure 9. 10-minute walk from schools

3.2. **Theme 2: Bridges & Crossings**

The Canadian National Railway bisects Terrace – there are currently three crossing points of the rail line within the City. Two at-grade crossings are located at Frank and Kenney Streets on the west side of the City. The third crossing is the Sande Overpass, used by vehicles, pedestrians and cyclists which is located west of the Downtown. With the construction of the New Skeena Bridge in 1975, the Sande Overpass became the official route of Highway 16 through Terrace. During consultations the public identified safety as the biggest concern and barrier to active transportation in the Terrace area, with Sande Overpass identified as one of the most dangerous crossing points for pedestrian and cyclists, especially for those living in the Southside neighbourhood. Recommendations to improve Sande Overpass include:

4. **Improve pedestrian and cycle friendliness of Sande Overpass** (see Figure 10):

- Install interior railings on the overpass sidewalks.
- Upgrade gravel shoulders at north and south ends of Sande Overpass to paved shoulders to accommodate cyclists.
- Install a pedestrian-controlled traffic light at intersection of Sande and Keith Avenue.



Figure 10. Recommended improvements to Sande overpass



Figure 11. Sande overpass

The Old Skeena Bridge is a one-way bridge that provides access from downtown Terrace across the Skeena River to Thornhill. Formerly the route of Highway 16, this heritage bridge has been identified as the most desirable active transportation to link Terrace and Thornhill across the Skeena River. Currently, cyclists are not allowed on the bridge deck, and the existing sidewalk is too narrow to accommodate both cyclists and pedestrians. Recommendations to improve the Old Skeena Bridge include:

5. In conjunction with the Ministry of Transportation undertake further study of the Old Skeena Bridge to investigate the following options:
 - Suspending a separate bi-directional cyclist bridge beneath the existing bridge.
 - Widening the existing sidewalk to accommodate bi-directional multi-use travel (And moving the existing light poles to the outside of the sidewalk.)
 - Installing a bicycle travel lane with a bike-friendly surface on the existing open grated steel deck in combination with a cyclist activated warning signal.
6. Upgrade gravel shoulders on north side of Lakelse Road from Apsley to the Old Skeena Bridge to accommodate bicycles (see Figure 13).
7. **Install a multi use path on the south side of Lakelse Road from Apsley to the Old Skeena Bridge** (see Figure 13).
8. **Designate a crossing point on Lakelse Ave for east-bound cyclists and pedestrians to access the Old Skeena Bridge sidewalk by installing a bike box and an advance (push button) signal that allows cyclists and pedestrians to cross to the Old Bridge sidewalk on a red light** (see Figure 13).



Figure 12. Old Skeena Bridge. Cyclists are not allowed on the deck.

The Kalum River Bridge provides two-way access from Terrace west across the Kalum River. This bridge provides access to the City of Terrace for residents of the Kitsumkalum Reserve.

Recommendations to improve this crossing include:

9. Widen the existing sidewalk on the Kalum River Bridge.
10. Work with the Kitsumkalum Band to ensure plans for the extension of the Grand Trunk Pathway west across the bridge coordinate with the Bands' plans for active transportation routes to and from the reserve.

The New Skeena Bridge is a two-way bridge, and the route of Highway 16 across the Skeena River to Thornhill. Currently, the bridge has a sidewalk on the north side only. Cyclists are permitted to ride on the bridge deck. Recommendations to improve this crossing include:

11. Undertake engineering and design analysis for a pedestrian and cyclist friendly underpass at the western end of the New Skeena Bridge (see Figure 13).
12. In the long term, widen the sidewalk on the New Skeena Bridge to accommodate two-way traffic of pedestrians and wheelchairs (see Figure 13).

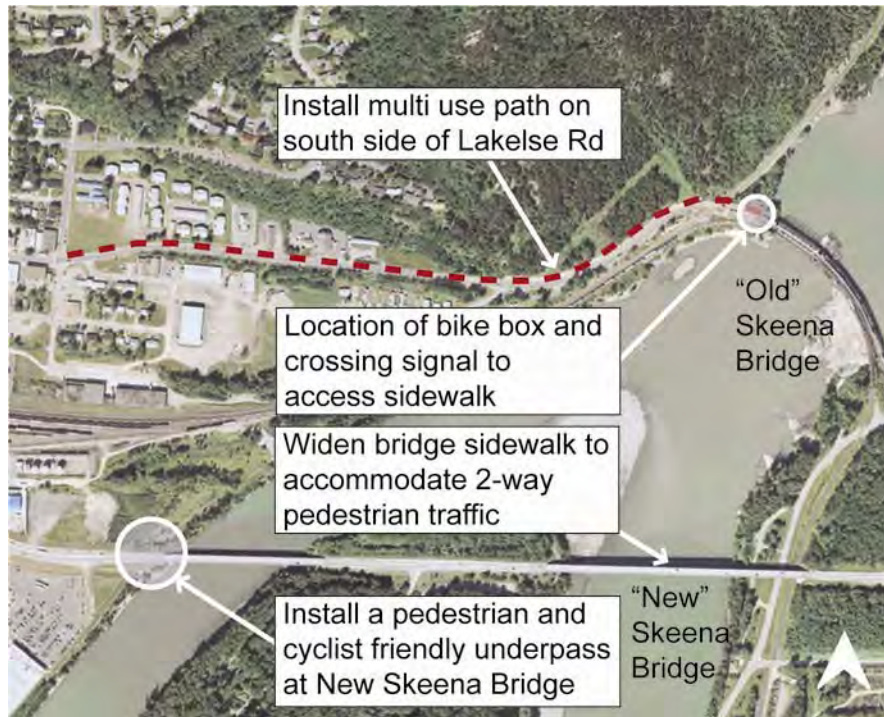

Figure 13. Recommended improvements to the old and new Skeena Bridges.

Development of a new overpass is under consideration and was the subject of a 2008 study commissioned by the City of Terrace, CN Rail and ICBC. The Terrace Transportation Corridor Study looked at three options and identified Kenney Street and Kalum Lake Drive as the preferred locations for a future vehicle overpass. Establishing an overpass east of Sande at Kalum Street was not considered as an option because of the width of the rail yard at this location, which would require a long bridge span. However, establishment of a pedestrian- and cyclist-only overpass at this location is worth consideration because of the lack of active transportation access to the Southside. An overpass at this location would benefit Southside residents by providing direct access to downtown, the Sportsplex, and George Little Park, providing a safe crossing point for youth commuting to school, and improving access to Ferry Island and future recreational loops once the Grand Trunk Pathway is extended to Kalum Street. A construction right-of-way at Kalum Street across the rail line exists which would facilitate construction of a pedestrian/ cyclist overpass at this location.

13. **Construct a new pedestrian and cyclist overpass at Kalum Street** (see Figure 14). An example of similar overpass project in Port Moody is profiled in Appendix C: Best Practices.
14. Include pedestrian and cycling facilities in any future rail grade separation project.

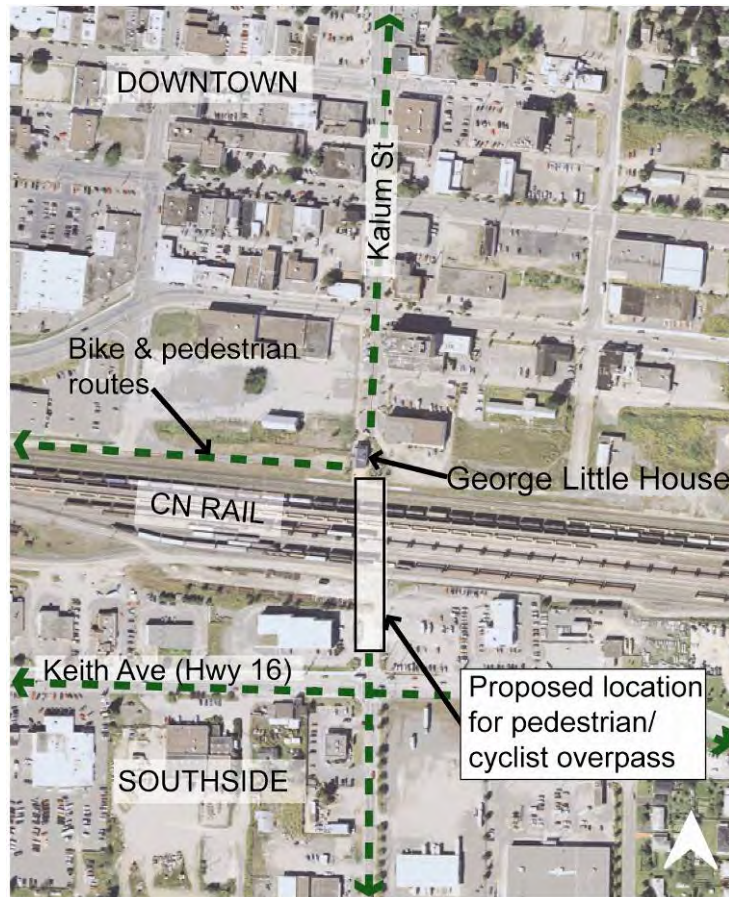

Figure 14. Proposed Kalum Street Pedestrian & Cyclist Overpass.

3.3. Theme 3: The Benches

The areas known as “the Bench” and “the Birch Bench” are characterized by their location at the top of an escarpment. Access to these mainly residential areas is via steep roads that lack sufficient bicycle facilities and sidewalks, making active transportation difficult as a viable means of transportation for Bench and Birch Bench residents. The Bench area has two schools including the Northwest Community College.

Recommendations to improve active transportation in the Bench Neighbourhood include:

15. Construct a staircase in the Howe Creek Trail System at the foot of Eby Street to provide AT access to the Bench. This staircase should have lighting, and a bike rail so that cyclists can walk their bikes while using the staircase (see Figure 15).
16. **Construct a staircase in the Howe Creek Trail System at the foot of Thomas Street to provide AT access to the Bench.** This staircase should have lighting, and a bike rail so that cyclists can walk their bikes while using the staircase (see Figure 15). (See also Appendix C: Best Practices)

17. Undertake a geotechnical study to determine if one or more paved trails at less than 8% maximum grade can be established in the Howe Creek Trail System to provide an alternative universal access route to the Bench (see Figure 15). (See Appendix B: Design Guidelines Section 4.5).



Figure 15. Recommendations to access the Bench.

18. Install Share the Road Signs (TAC Sign W11-1 / W16-1) on Lanfeer Drive and Skeenaview Drive at 200m intervals to warn vehicle drivers that cyclists may be present on the roadway (see Appendix D: Signage Schedule).
19. Install traffic calming at the base of Lanfeer Drive with a raised crosswalk and advance signage using TAC WC-46 Bicycle and Pedestrian Crossing Ahead to alert motorists to pedestrians and cyclists crossing Lanfeer to access the Howe Creek Trails (see Figure 16) (see Appendix D: Signage Schedule). In the long-term install a pedestrian and cyclist activated crossing light at this location.
20. Designate the following Bench roads as signed bicycle routes using TAC IB-23 route marker signs and painted bicycle symbols on pavement (see Appendix D: Signage Schedule):
 - Halliwell Ave (from Sparks to Thomas Street)
 - McConnell Avenue (from Thomas to Kalum Lake Drive)
 - Thomas Street (from Halliwell to McConnell)
 - Eby Street (from Howe Creek Trail to Halliwell)
 - Anderson Street (from Skeenaview Drive to Halliwell Ave)
 - Kalum Lake Drive (from Floyd Street to Highway 16)

- Floyd Street (from Kalum Lake Drive to McConnell Avenue)



Figure 16. Recommendations for Lanfear Drive

21. Use miniature TAC IB-23 symbols on road name signs for all roads designated as bicycle routes (see Appendix D: Signage Schedule).
22. Formalize trail access to the Birch Bench by upgrading and paving the existing trail at Olsen Avenue.
23. **Formalize trail access to Northwest Community College by upgrading existing trail between Mountain Vista Drive and Floyd Street.**

3.4. **Theme 4: The Downtown**

The Downtown is characterized by a compact, walkable retail area that has been the focus of a recent downtown revitalization effort by the City. The city has spent approximately \$2.8 million on projects aimed at downtown revitalization in 2009, including work on the extension of the Grand Trunk Pathway, a redesign of George Little Park and repaving of the brick walk on Lazelle Avenue. The City has also made a commitment to install additional banners, bike racks and lighting. The Downtown has some of the most pedestrian friendly features in the City including large shade trees, covered sidewalks, and pedestrian-controlled lights, but further pedestrianization and

improvements at busy intersections are needed to create a vibrant economic environment. There is a need for additional bike racks in all the commercial areas of the Downtown.

The following actions are recommended for the Downtown:

- 24. **Continue bike rack installation program by engaging local students or artists to design made-in-Terrace bicycle racks for the Downtown** (see Figures 17 and 18). Placement, installation, and design of bicycle rack is important to ensure they are usable (see Appendix B: Design Guidelines, Bicycle Racks). (See also Appendix C: Best Practices)

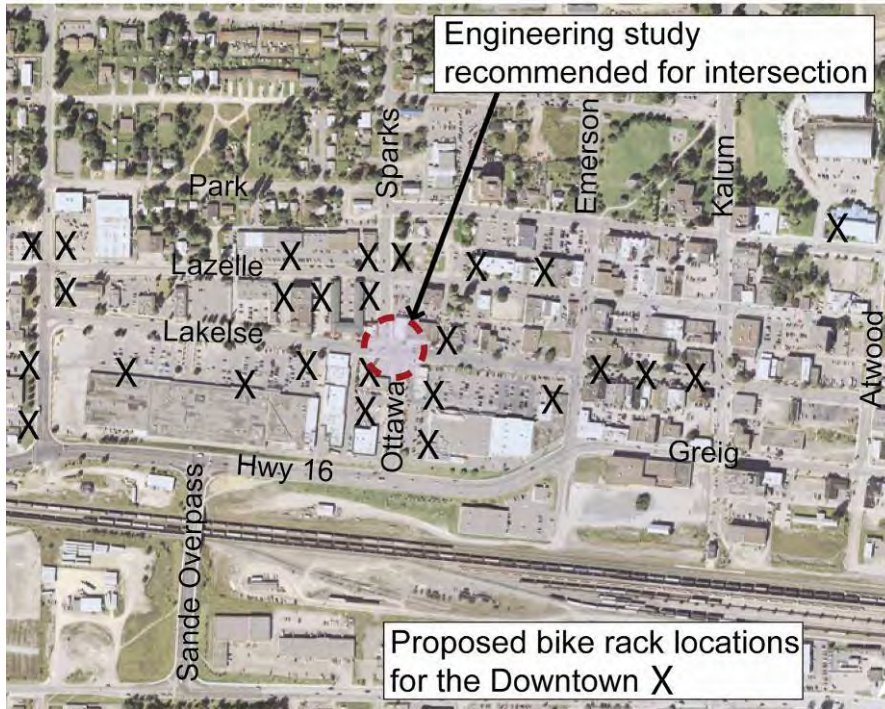

Figure 17. Proposed downtown bike rack locations.



Figure 18. Custom bike rack example.

25. **Undertake a traffic engineering study of the intersection of Lakelse, Sparks and Ottawa.** Look at traffic volume, traffic movement and signaling in order to reduce bicycle-vehicle conflict at this intersection (see Figure 17). Consider a bike box or advance light at this intersection.
26. Upgrade current signalized crossings to pedestrian-activated audible countdown signals.
27. Ensure curb cuts are present at all designated crossing points.

3.5. **Theme 5: The Southside**

Better pedestrian and bicycle connections across CNR / Highway 16 are key issues for Southside residents because the CN rail line and the highway separate the Southside from the rest of the community. The Skeena River defines the southern edge of the Southside, although active transportation access to the river is limited. The Southside has three schools, including the French immersion program, which enrolls youth from across the community. In general, the Southside is lacking in sidewalks and bicycle facilities. Community input to the Active Transportation Plan has revealed a strong desire for a recreational loop trail along the Skeena River.

Recommendations to improve active transportation in the Southside include:

28. Infill sidewalks on Keith Avenue between Kenney Street and the New Skeena Bridge, with a priority on establishing sidewalks in the east near Sande Overpass.
29. Designate the following Southside roads as signed bicycle routes using TAC IB-23 route marker signs and painted bicycle symbols on pavement (see Appendix D: Signage Schedule):
 - Kenney Street (from Highway 16 to Graham Ave)
 - Graham Ave (from Kenney Street to Kalum Street)
 - Keith Avenue (from Kenney Street to Sande Overpass)
 - Eby Street (from Keith Avenue to Graham Avenue)
 - Kalum Street (from Keith Avenue to Graham Avenue)
 - Haugland (from Tetrault Street to Eby Street)
30. Use miniature TAC IB-23 symbols on road name signs for all roads designated as bicycle routes (see Appendix D: Signage Schedule).
31. **Undertake corridor acquisition to establish a Riverside Trail recreational loop along the Skeena River that links Fisherman's Park to the New Skeena Bridge** (see Figure 19). (See also Appendix C: Best Practices)

A viable AT trail along the river will require the establishment of authorized public access across several properties. Authorized access to private lands for public trails can be achieved in various ways. Acquiring public rights-of-way is

recommended as the preferred solution. Alternative options include purchase, subdivision, or donation of a strip of land by a current owner, possibly in exchange for property enhancements or other benefit. The dedication of a riverside corridor should be reflected in the Official Community Plan and addressed by the City on a lot by lot basis.



Figure 19. Proposed Southside recreational trail loop.

3.6. **Theme 6: The Horseshoe**

Flat topography and proximity to the Downtown make the Horseshoe an ideal neighbourhood for active transportation. The Howe Creek Trail system is a well-used gravel and hard pack trail network at the base of the Bench escarpment that has many access points to the residential areas in the Horseshoe. A major issue in the Horseshoe is a need for traffic calming and pedestrian crossings along busy streets such as Kalum and Sparks Streets. The Horseshoe has five schools, as well as the Terrace Sportsplex, which houses the arena and aquatic centre.

Recommendations to improve active transportation in the Horseshoe include:

32. **Designate Park Avenue as a continuous east-west pedestrian and cyclist boulevard by creating connectors and installing sidewalks from Kalum Lake Drive to Apsley Street.** Enhancing the bike/pedestrian only connection just east of Munroe Street will increase the appeal of this street as an east-west priority route for non-motorized travel, and discontinuous route for cars (see Figure 20). (See also Appendix C: Best Practices)
33. Designate the following Horseshoe roads as signed bicycle routes using TAC IB-23 route marker signs and painted bicycle symbols on pavement. Upgrade to bicycle lanes as streets are repaved (see Appendix D: Signage Schedule).
 - Munroe Street
 - McConnell Avenue
 - Straume Avenue (from Thomas Street to Kalum Street)
 - Eby Street (from Olsen Street to Christy Park)
 - Kalum Street (from Scott Avenue to foot of Kalum)
 - Apsley Street (from Park Avenue to Lakelse Avenue)

- Sparks Street (from Davis Avenue to Park Avenue)

34. Use miniature TAC IB-23 symbols on road name signs for all roads designated as bicycle routes (see Appendix D: Signage Schedule).



Figure 20. Proposed pedestrian and bike boulevard - Park Avenue Connector

3.7. Theme 7: Transit

Recommendations to improve the integration of active transportation and transit facilities include:

- 35. Undertake a ridership survey to look at the transit systems in terms of levels of service, frequency, and potential for integrating smaller, more frequent community shuttles.**
36. Improve accessibility of sidewalks and pathways within a 5-minute (280m) walk of transit stops.
37. Improve transit stops and park & rides by installing bike racks at the 4-way park & ride location for residents who commute to Kitimat.
- 38. Install bike racks near transit stops where there is demand for short-term bike parking to prevent cyclists from locking bikes to transit poles which can be a problem for transit users.**
39. Providing benches, shelters, posted schedules, trash receptacles, bicycle parking and other features at major transit stops (see Figure 21).



Figure 21. Transit stop with shelter, bench and posted schedules

3.8. **Theme 8: Bicycle Parking**

It is important for cyclists who are using their bicycle for transportation or utilitarian purposes to feel there is a safe place to lock and leave their bicycles. The responsibility to provide bicycle racks should not only rest with the municipality, but also with merchants, hotel owners and government.

40. Provide Class I parking (i.e. bicycle lockers, locked bicycle rooms) at multiple unit dwellings, and places of employment such as offices, hotels, retail (see Appendix B Design Guidelines section 3.1).
41. Provide Class II parking (bicycle racks) at all public and institutional buildings including municipal buildings, library, arena, schools, daycares, and the hospital with restrictions on vehicle parking to ensure access to bicycle racks (especially multi racks).
42. Encourage all existing commercial establishments to provide bicycle racks. The City should adopt a bylaw requiring new commercial developments to provide bicycle racks.

3.9. **Theme 9: Maintenance**

43. Establish a municipal maintenance policy as described in Appendix B Design Guidelines (Maintenance).
44. Collaborate with local walking and cycling advocacy groups to create a Sidewalk Snow Removal Policy that outlines procedures for snow removal by the City, home and business owners. Put a top priority for snow and leaf removal on streets within a 10-min (200m) walk of schools, and next on streets with bicycle routes.

3.10. Theme 10: Education and Encouragement

It is important that the Active Transportation Plan be understood as more than just changes to the physical environment. Designing a pedestrian- and bicycle-friendly environment, and enhancing infrastructure will encourage more people to consider walking and cycling as a viable form of transportation. However, without adequate promotion, education, encouragement, and enforcement the goal of increased modal share will not be fully realized. Programs to promote walking and cycling and to educate cyclists and motorists as to how to safely share the road are needed.

The recommendations presented in Themes 1 - 7 are primarily infrastructure-oriented components which would be designed, constructed, or installed. This theme addresses programs rather than infrastructure – the “soft” rather than the “hard” aspects of an Active Transportation Plan.

Awareness and encouragement programs are intended to improve the perception and acceptance of active transportation in the community, by making people more aware of the presence and opportunities for walking and cycling, and by motivating people to use multi modal forms of commuting.

Recommended programs include:

45. Develop a wayfinding signage strategy for recreational trails including the Howe Creek Trails, Grand Trunk Pathway, and Ferry Island Trails.

Coordinate with the Regional District of Kitimat-Stikine to create a consistent branding of recreational routes across jurisdictions (see Figure 22). (See Appendix D: Signage Schedule)



Figure 22. Examples of wayfinding signage.

46. Develop a Community Cycling Map and Walking Map to complement the existing Terrace Trails Map (see Figure 23).

The Cycling Map should identify the location of bicycle routes, bicycle parking, bicycle shops and rental locations. The Walking Map should identify recreational loops, and key City landmarks. These maps should be distributed to residents and businesses, and made available at the Visitor Information Centre, City Hall, and local shops. The cost of producing the map can be partially or fully off-set by revenues from a partnership/sponsorship or advertising included on the map.



Figure 23. Examples of community cycling & walking maps⁵.

47. Initiate a Terrace Bike to Work Week challenge. See Bike to Work BC’s website at www.biketowork.ca/bc_communities/news/results for resources on developing a Bike to Work Week and to register as a community.
48. Encourage community naming of bicycle trails and routes to promote the community’s sense of ownership.
49. Encourage businesses to offer incentives if you bike to their store, similar to store incentives for bringing your own bag or coffee mug. Recognize positive contributors in the business community.
50. Hold a bike festival annually during the month of May (bicycle month), or to coincide with Transportation Week (early June). The festival can include many types of activities such as the opening of one of the designated bike routes or the Grand Trunk Pathway extension, a bike to the river day, a commuter challenge, a pancake breakfast, a transportation fair, or a positive enforcement day. These are several examples of successful promotional programs generally co-ordinated, at least in part, by volunteers.

3.10.1. Education Programs

Education programs are designed to inform and educate cyclists and motorists about “sharing the road” and how to co-exist in a safe and mutually respectful manner. Many types of cyclist skills educational programs and materials have already been developed and are provided in communities across Canada, and would require little or no modification for use in Terrace.

Recommended education programs include:

51. Build on the success of the Bike Rodeos by supporting the implementation of fall/spring cycling education programs in schools such as:

⁵ Maps available at (as pictured from left to right): Winnipeg Cycling Map: <http://biketothefuture.org/commuter-cyclists-resources/tips/winnipeg-cycling-map>; Vancouver Bicycle Route Map: <http://vancouver.ca/engsvcs/transport/cycling/documents/bikeRouteMap.pdf>; Whitehorse Commuter Cycling Map: <http://www.tc.gc.ca/programs/environment/utsp/docs/Whitehorse1.pdf>; Kelowna Self-Guided Walking Tour Map: <http://www.artsinkelowna.com/images/Inside%20Panel.pdf>.

- ICBC's provincial *Way to Go!* School Program (www.waytogo.icbc.bc.ca).
- The Canadian Cycling Association's national CAN-BIKE education program (www.canadian-cycling.com/cca/education/canbike.shtml) which offers programs for both children and adults.
- The Greater Victoria Cycling Coalition has produced the *BikeSense Manual* available on-line (www.bikesense.bc.ca) which contains detailed information on CAN-BIKE and One-Day Commuter Skills courses, as well as other cycling safety and skills workshops available in British Columbia.

3.10.2. Enforcement Programs

Enforcement programs are designed to apply the rules of the road and emphasize the rights and responsibilities of *all* road users. It is important that enforcement is preceded by education. Enforcement issues that have been brought forward include:

- Need for enforcement of parking restrictions so people do not park in bike lanes.
- Need for compliance around helmet use, riding bicycles on sidewalks and illegal crossings, which create safety concerns.
- Educational ticketing (e.g. take a course or pay a fine) or informational ticketing (e.g. a violation ticket without a fine) could be part of an enforcement program, particularly in the downtown where auxiliary forces are used.
- Suggestion to enhance involvement of enforcement in planning, design, and operation of pedestrian facilities.

3.10.3. Involving the Community in Implementation

As the Active Transportation Plan is implemented, it will be important to ensure that it continues to meet the needs of residents, employees and visitors. This is best accomplished by involving the community in the process of implementing and “fine-tuning” the plan.

Another important reason for involving the community is to draw on the specialized expertise and volunteer effort available in the community. Many local governments are hampered by limited human and financial resources, particularly in implementing awareness, encouragement, and education programs. In addition, municipal staff may lack specialized expertise in a particular area of active transportation planning and design.

In Terrace, a Transportation Working Group has been established as part of the Terrace 2050 Visioning process. This committee can provide the community – residents and visitors, cyclists, and non-cyclists – with a means of bringing forth their ideas, concerns, and comments regarding ongoing active transportation initiatives in Terrace as the Active Transportation Plan is implemented.



ACTIVE TRANSPORTATION PLAN
December 2009

LEGEND	
On-Road Facilities	
	Existing Road Bicycle Lanes
	Proposed Signed Road Bicycle Route
Off-Road Facilities	
	Existing Off-Road Recreational Trail
	Proposed Off-Road Recreational Trail
	Proposed Staircase (with Bike Rail)
	Proposed Cyclist/Pedestrian Overpass
Other	
	Rail Line
	Access point to Terrace Mtn Trails
	School
	Bridge

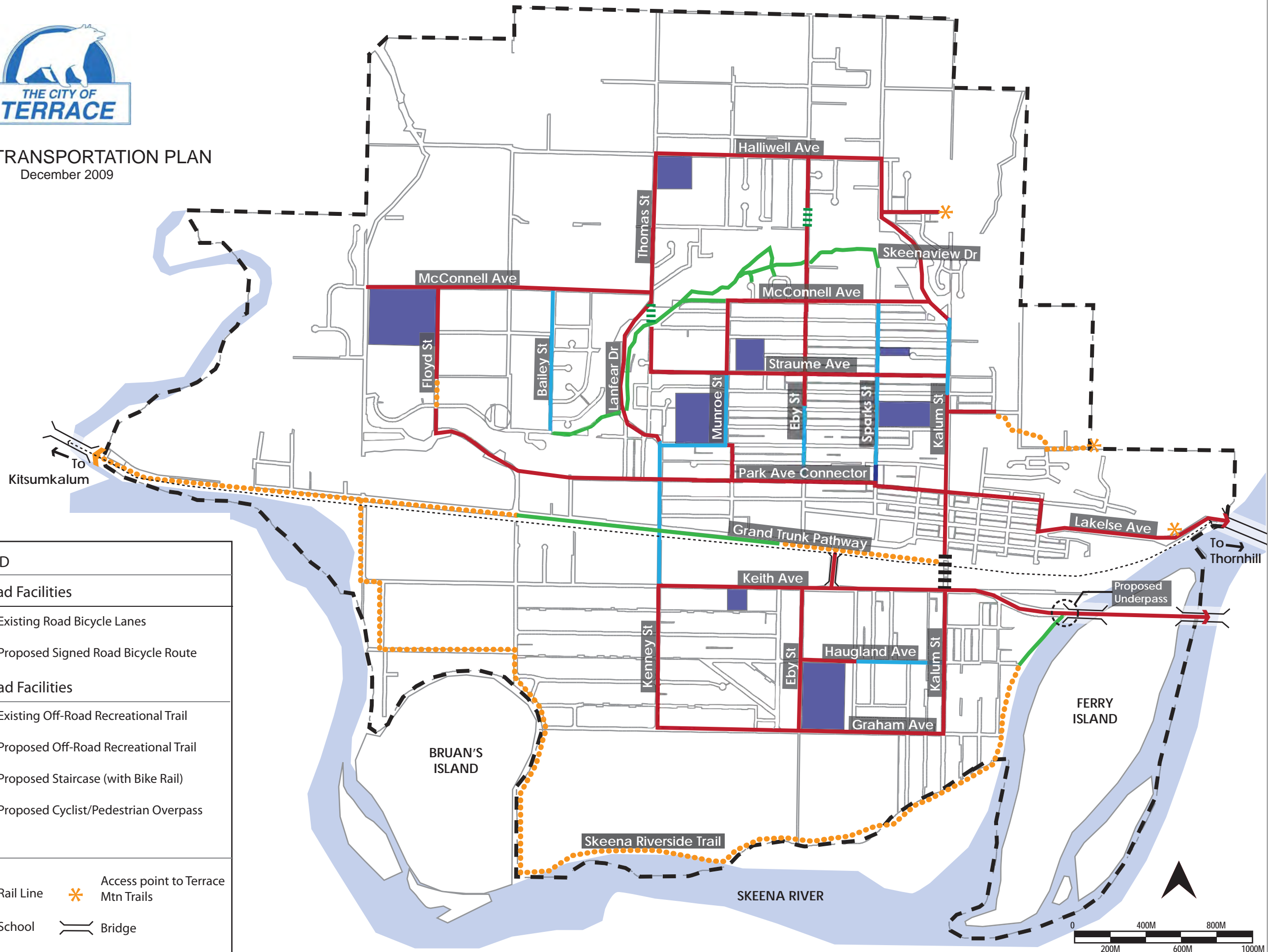

PRIORITY PROJECTS

- Build and upgrade sidewalks within a 10-min walk from schools
- Improve pedestrian and cycling friendliness of Sande Overpass
- Install a multi use path on the south side of Lakelse Road from Apsley to the Old Skeena Bridge
- Install a crossing point (bike box & signal) at end of Lakelse Ave to access the Old Bridge sidewalk
- Construct a Pedestrian and Cyclist Overpass at Kalum Street
- Construct a staircase to the Bench at the foot of Thomas Street
- Formalize trail access to NWCC between Mountain Vista Dr and Floyd St
- Install custom made-in-Terrace bike racks in the Downtown
- Undertake a traffic engineering study of the intersection of Lakelse, Sparks and Ottawa
- Establish a Riverside Trail recreational loop along the Skeena River
- Designate Park Ave as an E-W pedestrian/cyclist Boulevard
- Undertake ridership survey for local transit system
- Install bike racks near transit stops where there is demand for short term bike parking
- Develop a signage strategy for recreational trail systems
- Develop a Community Cycling Map and Walking Map



Figure 24: Bicycle Network Map



ACTIVE TRANSPORTATION PLAN
December 2009

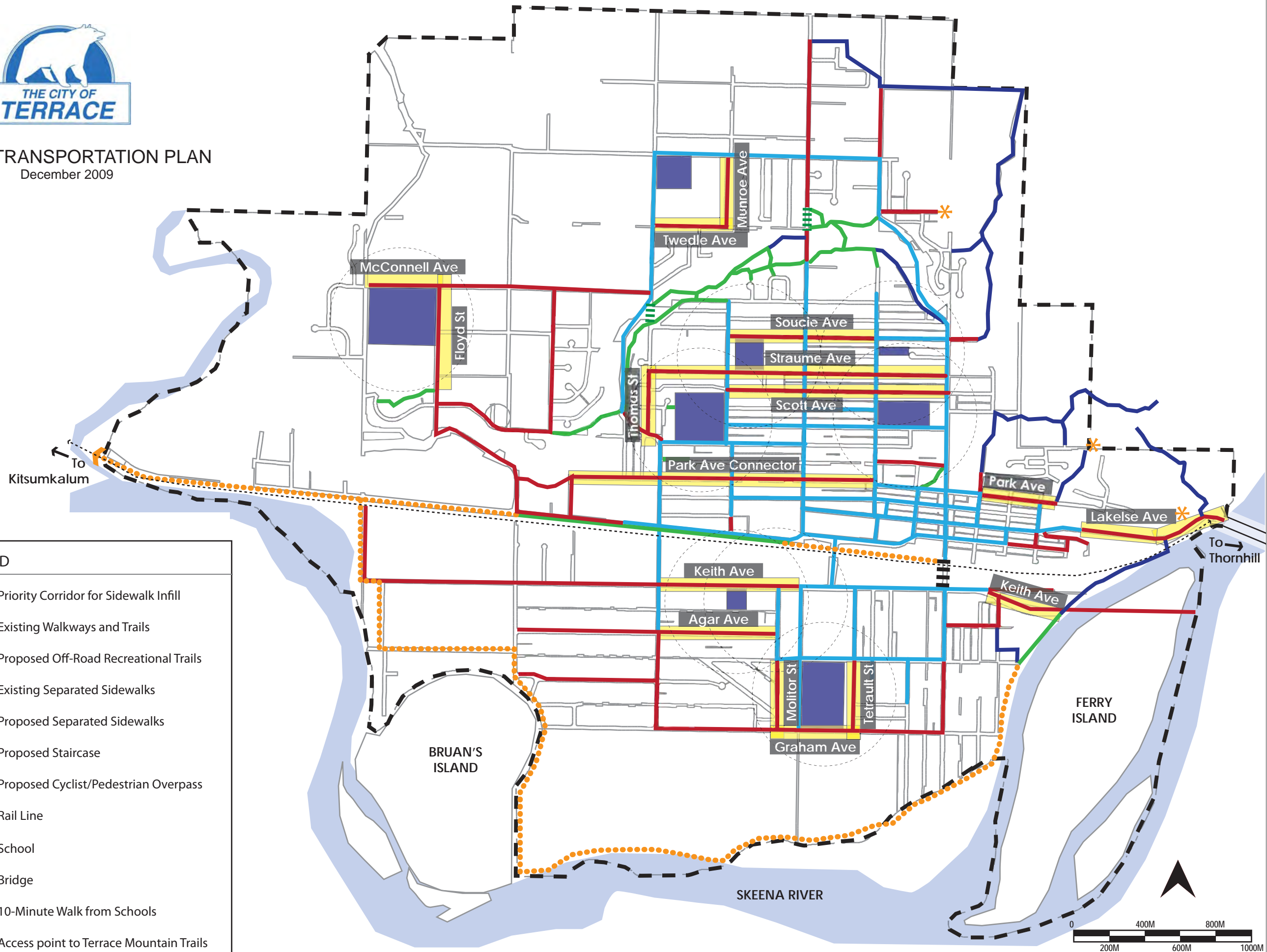

Priority Corridors for Sidewalk Infill:

- 1 - Park Ave Connector
- 2 - Lakelse Ave (to Old Skeena Bridge)
- 3 - Keith Ave (Kenney St to New Skeena Bridge)
- 4 - Sidewalks within a 10-minute walk (280m) from schools

NOTES:

Sidewalks degrade over time due to tree roots, weathering and other factors. Cracks, uneven surfaces and pavement heaving will appear. The City should develop a program to repair or replace damaged and deteriorated sidewalks where surfaces have degraded. In addition, a number of sections should be added to the network each year, depending on funding availability. The pedestrian corridors noted above should take priority for sidewalk infill and improvement.

LEGEND

- Priority Corridor for Sidewalk Infill
- Existing Walkways and Trails
- Proposed Off-Road Recreational Trails
- Existing Separated Sidewalks
- Proposed Separated Sidewalks
- Proposed Staircase
- Proposed Cyclist/Pedestrian Overpass
- Rail Line
- School
- Bridge
- 10-Minute Walk from Schools
- Access point to Terrace Mountain Trails



Figure 25: Pedestrian Network Map

3.11. Changes to Related Policy Documents

3.11.1. Official Community Plan

In order for the Active Transportation Plan to be effective, it must first receive the support of City Council and staff. Once accepted as policy, the Plan should be used as a guideline in annual budgeting and to accomplish the tasks laid out in the Plan. The Plan should also be reviewed on a regular basis to identify accomplishments, and to revise the goals and the implementation strategy. The best way to accomplish the recommendations in this study is to “institutionalize” the policies herein. This means that the recommendations need to be seen as benefiting the entire transportation network, not just bicycles and pedestrians.

Currently, the Official Community Plan (OCP) contains limited mentions of cycling and walking. The following OCP amendments are recommended for the OCP update to ensure that walking and cycling are:

- Clearly identified as a viable transportation alternatives and an integral part of the transportation network;
- Accommodated during all roadway planning, design and construction undertakings, and
- Not compromised in order to enhance facilities for other motorized vehicular transportation modes, excluding transit.

To ensure that the City develops its mobility system as an integrated, multimodal system, the relationship between each mode and the relative priority of each mode should be clearly defined in the OCP. In order to identify the specific relationship between various modes of transportation, it is suggested that active transportation policies be added to the transportation section of the OCP.

Recommended additions to the Official Community Plan include:

- “The transportation system in Terrace is intended to provide for the efficient movement of people and goods, by all modes of transportation including pedestrians, bicycles, transit, trucks, delivery vehicles, and the private automobile.”
- “The integrated transportation system will place priority on non-single occupancy vehicle and non-motorized modes.”
- “Emphasis will be placed on increasing opportunities for non-automobile transportation modes, reducing the number of single occupancy automobile trips in the City of Terrace, and by supporting and encouraging bicycle use and pedestrian travel.”
- “Mobility planning initiatives should reflect the following priorities:
 - Pedestrian
 - Bicycle
 - Transit
 - Multiple-occupant vehicles
 - Goods movement

- Single-occupant vehicles.”
- “All new developments and amenities in the City of Terrace must provide facilities to accommodate pedestrian and bicycle access.”
- “The City shall adopt the City of Terrace Active Transportation Plan.”
- Update Schedules ‘F’ and ‘E’ to match the alignments shown in this Plan.

Development Permit or Zoning policies can include guidelines for cycling and pedestrian facilities such as cycle lanes and multi-use pathways, bike parking, and sidewalks to support active transportation use. When the City’s Engineering Standards are revised, updating provisions for accessible pedestrian facilities and cycling facilities in new road classes should be considered.

4. Plan Implementation

4.1. Funding Opportunities

At the present time, funding (other than from the local Terrace tax base) for alternative transportation infrastructure and improvements is increasing, thanks to increased awareness of walking and cycling as a means of reducing traffic congestion and green house gas emissions, and of the benefits of active living. Implementation of the Active Transportation Plan can be expedited by seeking alternative sources of funding other than traditional tax-base funding.

See Appendix E for a list of alternative funding sources, as well as variations on tax-base funding, which can be used to finance the various components of the plan.

4.2. Priority Projects and Phasing

The following prioritized list of action items (Table 6) is proposed in order to achieve the vision outlined in this plan. The realization of the proposed active transportation network will require long-term vision, and on-going collaboration between City of Terrace staff and community partners. Timing of projects and improvements will ultimately depend on the success of funding initiatives and interest and availability of community partners.

Fifteen high priority projects have been chosen (highlighted in blue) based on feedback received at the public consultations and the consultant’s technical review. These are projects that should be undertaken in the next 15 years, and should form the focus of future efforts to enhance the Terrace active transportation network.

A digital copy of the Action Plan will be provided to the City so that it can be updated as action items are realized.

ACTION PLAN				
#	Recommendation	Timeline	Capital Costs	Possible Partners / Resources Required
THEME 1 - SCHOOLS				
1	Discourage vehicle parking within a 5-minute walk of schools 30 minutes either side of school opening and closing	1	\$	Staff
2	Build and upgrade sidewalks within a 10-minute walk from schools	2	\$\$	Staff
3	Implement a program to walk and bike along safe routes to schools	2	\$	Community Partners
THEME 2 - BRIDGES & CROSSINGS				
4	Improve pedestrian and cycling friendliness of Sande Overpass and intersection	3	\$\$\$	Staff/Consultant
5	Undertake further design/engineering study of 3 options to improve access on the Old Skeena Bridge	1	\$	Consultant
6	Upgrade gravel shoulder on north side of Lakelse Road from Apsley to the Old Skeena Bridge	2	\$\$	Staff
7	Install a multi use path on the south side of Lakelse Road from Apsley to the Old Skeena Bridge	2	\$	Staff
8	Install a bike box & signal upgrade at end of Lakelse Ave to allow peds/cyclists to access the bridge	1	\$	Staff/Consultant
9	Work with the Kitsumkalum Band to coordinate extension of the Grand Trunk Pathway west across the Kalum River	1	\$\$	Staff
10	Undertake engineering and design analysis for underpass at the western end of the New Skeena Bridge	1	\$	Consultant
11	Widen the existing sidewalk on the Kalum River Bridge	3	\$\$\$	Consultant
12	Widen north sidewalk on the New Skeena Bridge to accommodate two way traffic of pedestrians/wheelchairs	3	\$\$\$	Consultant
13	Construct a Pedestrian and Cyclist Overpass at Kalum Street	3	\$\$\$	Staff/Consultant
14	Include pedestrian and cycling facilities in any future rail grade separation project.	1	\$	Staff
THEME 3 - THE BENCHES				
15	Construct a staircase in the Howe Creek Trail System at the foot of Eby Street	2	\$\$\$	Staff/Consultant
16	Construct a staircase to the Bench at the foot of Thomas Street	2	\$\$\$	Staff/Consultant
17	Undertake geotech study to determine if one or more paved trails at <8% grade can be established to Bench	1	\$\$	Consultant
18	Install Share the Road Signs on Lanfear Drive and Skeenaview Drive	1	\$	Staff
19	Install traffic calming at the base of Lanfear Drive with a raised crosswalk and advance warning signage	2	\$\$	Staff
20	Designate signed Bench bicycle routes using route marker signs and painted bicycle symbols	1	\$	Staff
21	Use miniature Bike Route symbols on road name signs for all roads designated as bicycle routes.	1	\$	Staff
22	Formalize trail access to the Birch Bench by upgrading and paving the existing trail at Olsen Avenue	2	\$\$	Staff/Community Partners
23	Formalize trail access to NWCC by upgrading existing trail between Mountain Vista Drive and Floyd Street	2	\$\$	Staff/Community Partners
THEME 4 - THE DOWNTOWN				
24	Continue bike rack program by installing custom made-in-Terrace bike racks in the Downtown	1	\$	Staff/Community Partners
25	Undertake a traffic engineering study of the intersection of Lakelse, Sparks and Ottawa	1	\$	Consultant
26	Upgrade current signalized crossings to pedestrian-activated audible countdown signals	1	\$\$	Staff/Consultant
27	Ensure curb cuts are present at all designated crossing points	2	\$\$	Staff
THEME 5 - THE SOUTHSIDE				
28	Install sidewalks on Keith Avenue between Kenney Street and New Skeena Bridge	3	\$\$\$	Staff
29	Designate the Southside bicycle routes using route marker signs and painted bicycle symbols	1	\$	Staff
30	Use miniature Bike Route symbols on road name signs for all roads designated as bicycle routes	1	\$	Staff
31	Undertake corridor acquisition to establish a Riverside Trail recreational loop along the Skeena River	3	\$\$\$	Staff
THEME 6 - THE HORSESHOE				
32	Designate Park Ave as an E-W pedestrian/cyclist connector with continuous bike route and sidewalks	2	\$\$	Staff
33	Designate Horseshoe signed bicycle routes using route marker signs and painted bicycle symbols	1	\$	Staff
34	Use miniature Bike Route symbols on road name signs for all roads designated as bicycle routes	1	\$	Staff
THEME 7 - TRANSIT				
35	Undertake ridership survey for local transit system	1	\$	Staff/BC Transit
36	Improve accessibility of sidewalks and pathways within a 5-minute (280m) walk of transit stops	2	\$\$	Staff/BC Transit
37	Install bike racks at the 4-way park & ride	1	\$	Staff
38	Install bike racks near transit stops where there is demand for short term bike parking	1	\$	Staff
39	Provide benches, shelters, posted schedules, bicycle parking and other features at major transit stops	2	\$\$	Staff/BC Transit

THEME 8 - BICYCLE PARKING				
40	Provide Class I parking at multiple unit dwellings and places of employment such as offices, hotels and retail	1	\$	Staff
41	Provide Class II parking (bicycle racks) at all public and institutional buildings	1	\$	Staff
42	Encourage all existing commercial establishments to provide bicycle racks	1	Nil	Staff/Community Partners
THEME 9 - MAINTENANCE				
43	Establish a municipal maintenance policy as described in Appendix B (Maintenance)	1	\$	Staff
44	Collaborate with local walking and cycling advocacy groups to create a Sidewalk Snow Removal Policy	1	\$	Staff/Community Partners
THEME 10 - EDUCATION AND ENCOURAGEMENT				
45	Develop a wayfinding signage strategy for recreational trail systems, coordinated with RD Kitimat-Stikine	1	\$	Staff/ RDKS
46	Develop a Community Cycling Map and Walking Map to complement the existing Terrace Trails Map	1	\$	Staff/Community Partners
47	Initiate a Terrace Bike to Work Week challenge	1	\$	Community Partners
48	Encourage community naming of bicycle trails and routes	1	Nil	Community Partners
49	Encourage businesses to offer incentives if you bike to their store	1	Nil	Community Partners
50	Hold a bike festival annually during the month of May (bicycle month) or to coincide with Transportation Week	1	\$	Community Partners
51	Build on the success of Bike Rodeos by supporting implementation of cycling education programs in schools	1	\$	Community Partners/RCMP
Timeline Legend: Project Duration				
Short - Completion within 0 to 3 years of initiation				
Medium - Completion within 3 to 7 years of initiation				
Long - Completion within 7 to 15 years of initiation				
Costing Legend:				
\$ 1 - 10,000				
\$\$ 10,000 - 100,000				
\$\$\$ 100,000+				
Priority Project				

Table 6. Action plan.

References

Benefits of Investing in Active Transportation. Built Environment and Active Transportation Initiative, 2008.

Economic Benefits of Bicycle Infrastructure Investments. League of American Bicyclists, 2009.

Statistics Canada. *Terrace, British Columbia* (table). *2006 Community Profiles*. 2006 Census. Statistics Canada Catalogue no. 92-591-XWE. Ottawa, 2007.

<http://www12.statcan.ca/census-recensement/2006/dp-pd/prof/92-591/index.cfm?Lang=E>

Traffic Collision Report. British Columbia Motor-Vehicle Branch, 2007.

Transport Canada, "The Links between Public Health and Sustainable and Active Transportation." Urban Transportation Showcase, 2006.

Appendix A: Summary of Public Consultation Feedback

Summary of Input from Staff

The following staff will be providing input at various stages of the planning process. Key input and feedback is documented herein.

City Staff

1. Tara Irwin, Sustainability Coordinator
 2. David Block, City Planner
 3. Marvin Kwiatkowski, Director of Development Services
-

JULY 29, 2009: Initial Discussions

1. Kenney Street has safety problems for pedestrians and cyclists. This is also a connection for kids commuting to school.
2. Park Avenue is a good candidate for bike lanes.
3. The bench is difficult to access for pedestrians and cyclists because of steep grades and lack of adequate sidewalks, bike lanes. The AT plan should look at ways to improve access to the bench.
4. Railway crossings are a key issue. An overpass study looked at three options, with Kenney Street was recommended as the preferred option.
5. Creating linkages and improving safety should be priorities for the plan.
6. The transit system needs to be looked at. Running community shuttles may be more realistic than large buses.

Summary of Input from Stakeholder Interviews

EVENT #1: Stakeholder Interviews
LOCATION: City Hall Training Room
DATE: Wednesday July 29 - Thursday July 30, 2009
TIME: 1 hr per interview
FACILITATION: LEES + Associates Erik Lees, Heidi Redman
 dpl Consulting Danelle Laidlaw
 City of Terrace Tara Irwin, Sustainability Coordinator

Representatives from the following stakeholder groups were interviewed:

GROUP NAME	REPRESENTATIVE
1. Terrace RCMP	Carlos Tettolowski; Cindy Nunes
2. Regional District of Kitimat-Stikine	Andrew Webber
3. School Board/Sustainability Task Force	Diana Penner
4. Measuring Up the North Committee	Brenda; Yvonne; Gail Billson

The following is a summary of the most important needs, issues, concerns and suggestions that were brought forward:

1. Lack of compliance around helmet use, riding on sidewalks and illegal crossings are major safety concerns identified by the local RCMP. In addition to yearly bike rodeos and school talks, ads in the paper, educational ticketing, and use of auxiliaries in educational programs could be part of the solution. Have fun with public education strategies. Lack of compliance regarding parking on sidewalks and in bike lanes was identified by users.
2. The downtown core could be further pedestrianized with signage, landscaping and pedestrian-controlled crossings. Improvements on Lazelle are well received.
3. Lack of sidewalks and designated cycling facilities often leads to conflicts with vehicles. This could be alleviated through traffic calming measures such as traffic circles, curb bulges, raised pedestrian crossings. On some streets, such as Sparks, vehicles travel too fast and the speed limit should be lowered to 30km/hr.
4. There is a lack of active transportation facilities in residential areas (sidewalks and bike lanes). The South side in general needs more sidewalks and active transportation facilities. North Terrace is mainly large (10+acre) lots and so is less of a concern.
5. Specific areas that require AT improvements include:
 - o Sande overpass (not pedestrian friendly).
 - o The new bridge lacks a sidewalk on the south side.
 - o Intersection between Safeway and the Skeena Mall (Sparks & Lakelse) (accidents have occurred at this intersection).
 - o Schools (improve conditions for kids walking to school in winter).
 - o Northwest Community College needs an AT link (bike trail?) to downtown.

- Connection from Howe Creek to Lanfear has a dangerous crossing.
 - Keith is a problem on the South side.
 - The bike lane on Eby is too narrow and has a lip on the gutter pan.
6. Increased signage would be very helpful especially for seniors, and could be a key part of an educational and wayfinding strategy. The Terrace wayfinding strategy should be consistent with Thornhill in the long term. Hikers and bikers should work together on signage. Signage should include Braille, large print, and symbols for those who do not read. The length and difficulty rating of the trail should be indicated.
 7. Terrace has a great Trails Map that could be utilized in conjunction with education (i.e. sent to homes with friendly compliance reminders). A Cycling/Walking Map should be developed.
 8. Terrace has a good base of trails to build on, and most destinations in the City can be reached in 15-20 mins. However, trails within neighbourhoods could be improved. Trails to access the Terrace Mountain trails are needed. Trails in Howe Creek are very popular and some need steps with railings, re-grading, and possibly paving (erosion).
 9. A universal access loop trail on Ferry Island, a trail from Fisherman's Park to Ferry Island, and park/river access under the new bridge should be considered. The Walmart trail is good but currently does not go anywhere.
 10. Improving access to the bench is a high priority – this could be done using stairs near Eby/Christy Park. (Prince Rupert and Edmonton have some examples of hillside staircases). There may be room for a bike path on the right side of Kalum Lake Dr.
 11. Transit needs to be better promoted. There is some perception that if you don't have a car you are a second-class citizen. Bus service could be improved to Kitselas, Kitsumkalum and Thornhill. Smaller buses (shuttles) could be used on most routes and to the college. Coordination and scheduling of large buses is a constraint.
 12. More bike racks are needed throughout the City. Bike theft is high – but recovery rates are also high.
 13. Creatively designed, colorful bike racks could be used throughout town. Showers and end of trip facilities are also needed.
 14. Maintenance - winter plowing and maintenance of pedestrian routes is critical. Routine winter plowing should include cycling lanes. Highway shoulders should be cleaned at the end of winter.
 15. Measuring the use of facilities would be beneficial.
 16. Lighting is not a high priority, but some mentioned a desire for increased lighting on the Grand Trunk pathway.
 17. Pedestrian controlled signals with audible noise (for the blind) and a countdown should be considered. A lot of crosswalks are not well located and lack curb cuts.
 18. Terrace is a city by the river, but is not perceived as such. A riverfront trail from Kitsumkalum to the new bridge is a vision over the long term. Property issues are involved. The slough around Braun's Island would be a good destination for a recreational walking/cycling loop.
 19. Active Transportation standards are needed for new developments. Trails should be wide enough for a wheelchair and person side by side (see Tatlayoko Lake trail).

Summary of Input from Transportation Working Group

EVENT #2: Transportation Working Group – Working Lunch
LOCATION: Rich McDaniel Room
DATE: Thursday July 30, 2009
TIME: 12:00 – 2:00 PM
FACILITATION: LEES + Associates Erik Lees, Heidi Redman
 dpl Consulting Danelle Laidlaw
 City of Terrace Tara Irwin, Sustainability Coordinator

Transportation Working Group members in attendance:

NAME	REPRESENTING
1. Kevin Kilpatrick	Ministry of Forests
2. Bruce Martindale	City Council/ McBike cycling shop
3. Carla Briggs	Northwest Watch
4. Christine Slanz	Northwest Science & Innovation Society
5. Bert Husband	Terrace Standard, past chair Chamber of Commerce

The following is a summary of the most important needs, issues, concerns and suggestions that were brought forward:

1. The top three priorities for active transportation are:
 - o Access to the bench
 - o Railroad crossings
 - o Bridges
2. Bench Access – a switchback trail in the Howe Creek area is an alternative solution to Skeena View or Kalum Lake Drive. A paved and lit trail would provide more direct access to residences. This could happen at the pumphouse trail-Eby St or two other possible alignments. Stairs with bike push-ups are also an opportunity.
3. Railway Overpass – overpass needed at Kalum Street. This would provide links to Ferry Island, George Little house, Tourism Info Centre, and could tie into the Grand Trunk Pathway. Kamloops has a good precedent for a (covered) wooden overpass.
4. Thornhill – connection to the old bridge via Lakelse Ave needs to be addressed. This has the potential to be a beautiful link into downtown Terrace. This route is actively used and collisions are common. A separated bike path on Lakelse or an improved shoulder and crossing point are needed as bikes and pedestrians are required to use the bridge sidewalk, which is located on the north side. Small improvements on the Thornhill side would also make a big difference.

5. Kitsumkalum – the bridge to Kitsumkalum is too narrow for pedestrians and cyclists. It needs to be widened. A cantilevered addition may be an option. A link to Fisherman’s Park is important as there is lots of pedestrian activity here.
6. Waterfront – A walkway along the river is also desired as a long term vision. A dike (drainage mitigation) could double as a walkway. There is a precedent at Skaha Lake and may be one in Smithers. This has potential as a tourism route, ie. “Ribbon along the River” that would connect Fisherman’s Park to Ferry Island to the old bridge and then loop to downtown.
7. Eastside/ Kalum Housing – lots of pedestrian activity, yet only one crossing on Kalum. More crossings (pedestrian controlled) and traffic calming is needed.
8. Schools/kids – Sande overpass is perceived as dangerous - parents have safety concerns about letting their kids cross. It needs to be improved and railings on walkways. Also, bikes are not safe at school- good placement of racks is key, i.e. close to the school office.
9. Transit – suggest a ridership survey to look at transit.

Summary of Input from Terrace Bikeability Tour

EVENT #3: Biking Tour of Terrace with Community Partners
LOCATION: Depart from McBike bike shop
DATE: Friday July 31, 2009
TIME: 9:30 – 11:30 AM

The following people participated in the tour:

ORGANISATION

1. LEES + Associates
2. dpl Consulting
3. City of Terrace
4. McBike / City Council
5. Ministry of Forests

REPRESENTATIVE(S)

- Erik Lees, Heidi Redman
 Danelle Laidlaw
 Tara Irwin
 Bruce Martindale
 Kevin Kilpatrick

The key needs, issues, concerns and suggestions that were identified on the tour are documented below.

1. Bike lanes on the Bench – on the bench, Halliwell and Sparks could be a signed as bike routes. Kitselas is possible but it very steep.
2. Access to the Bench – several potential trail alignments from the horseshoe to the Bench were explored in the Howe Creek area.
3. Birch Hill Bench – this area needs trails to links to the downtown and to upland trails on Terrace Mountain.
4. Bike lanes in the Horseshoe – Straume was proposed as a bike route and an extension of the existing bike lane on Eby.
5. Pedestrian crossings in the Horseshoe – Lakelse at Emerson needs a pedestrian controlled light with a countdown. Add crosswalks to Park Avenue. A staircase for pedestrians is needed at the end of Straume.
6. Old bridge – a countdown crossing signal would be useful so people know how long they have to cross. The sidewalk on the bridge is too narrow and narrows to 95cm at light standards. Suggestion to create a separated path and/or improve bike lanes and sidewalks on Lakelse ave to bridge.
7. Southside - Pedestrian and cycling improvements are needed on Keith Ave.
8. Other – made-in-Terrace bike racks could be fabricated locally.



Improvements to Lakelse Ave and access to the Old Skeena Bridge should be a priority.



The group tours residential streets in the Horseshoe.

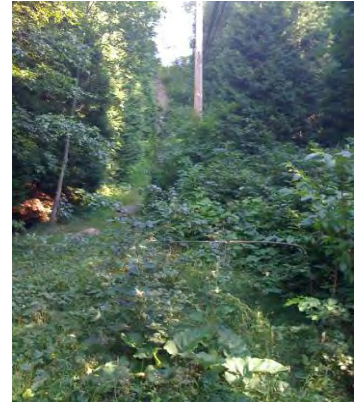

Suggested location for a staircase to the Bench.

Summary of Input from Walkability Tour

EVENT #4: Walkability Tour
LOCATION: Downtown Terrace
DATE: Friday July 31, 2009
TIME: 1:15 – 2:00 PM
FACILITATION: LEES + Associates Erik Lees, Heidi Redman
 dpl Consulting Danelle Laidlaw

The following stakeholders participated in the Walkability Tour:

ORGANISATION

1. Riverboat Days
2. City of Terrace
3. MLA – Skeena
4. Terrace Economic Development
5. Terrace Standard
6. City Council

REPRESENTATIVE(S)

Anna lee Davis
 Tara Irwin, David Block
 Robin Austin
 Sam Harling
 Kat Lee
 Bruce Martindale, Brian Downie, Carol Leclerc

The key needs, issues, concerns and suggestions that were identified on the tour are documented below.

1. The Downtown core needs pedestrian-controlled lights. Brick paving in the downtown core should needs maintenance to repair missing/damaged pavers.
2. Pocket parks in the downtown (eg. park next to Luck Garden Restaurant) are aesthetically appealing and are important gathering/resting places.
3. There is a lack of bike racks, especially in the downtown.
4. Handicapped parking next to George Little Park is not adequately signed and is too close to the parking lot entry.
5. Gutter pans in some bike lanes reduce the usable width of the lane. In winter, plowing of the bike lanes is needed. The group discussed Park Ave as a potential thoroughfare for bikes.
6. The intersection at Sparks and Lazelle, was identified as dangerous and difficult to navigate for pedestrians and cyclists. Traffic calming and a bike box were suggested as possible improvements.



Bruce Martindale points out the lip on the gutter pan in the bike lane on Sparks St.



The group discusses ways to improve the intersection at Sparks and Lakelse.

Summary of Input from Active Transportation Charrette

EVENT #5:	Active Transportation Charrette	
LOCATION:	Terrace Sportsplex	
DATE:	Thursday July 30, 2009	
TIME:	7:00 – 9:00 PM	
FACILITATION:	LEES + Associates	Erik Lees, Heidi Redman
	dpl Consulting	Danelle Laidlaw
	City of Terrace	Tara Irwin

The following stakeholders participated in the AT Charrette:

NAME	ORGANISATION
1. Guido Schnelzer	Resident
2. Kerry Giesbrecht	Resident/ Beautification Society
3. Kevin Kilpatrick	Sustainability Task Force
4. Val Parr	GTBS
5. Bert Husband	Sustainability Task Force/ Chamber
6. Bruce Martindale	Council
7. Kim Woodd	Resident
8. Jonathan Lambert	McElhanney Consulting
9. Carlos Tettolowski	RCMP
10. Amy LeClerc	GCMC
11. Paula Cousins	Ministry of Transportation
12. Dr. David Heiniman	Resident
13. Andrew Webber	Regional District
14. Carmen Didier	City of Terrace
15. Brian Downie	City of Terrace
16. Tony Moore	TORCA
17. Randy Penner	Ministry of Transportation
18. Lise Luppens	Resident
19. Christine Slanz	Northwest Science & Innovation
20. Brad Pollard	City of Terrace
21. David Block	City of Terrace
22. Tara Irwin	City of Terrace
23. Alison Johansen	Personal
24. Dave Pernarowski	City of Terrace
25. Rob Dykeman	TEDA
26. Curt Tuininga	Resident

The Open House included a community mapping exercise. Attendees mapped the pedestrian and cycling facilities they use (or would like to use) on aerial photos and added comments using sticky notes. The input and suggestions are summarized below.

INPUT FROM OPEN HOUSE - STICKY NOTES**LEGEND**

- (B) Transit
- (S) Sidewalks
- (P) Parking
- (R) Streets
- (RR) Railroad
- (T) Trail

B		Smaller buses
B		Improved Bus Stops
P		It would be great to have a bike lock up at the 4-way park & ride for people who commute to Kitmat
P		Ring and Post bike Racks throughout downtown
P		Bike racks at schools
P		Have employers provide showers, lockers for cycle commuters
P		Bike parking - welding classes
R		A bike lane to the old Bridge providing access to Thornhill, Twin River Estates
R		Cycling Routes to Parks, Schools, need to be continuous
R		Create bike route on Floyd, instead of Kalum Lake Dr
R		Developing the bridge loop as a recreational loop by rerouting from Keith onto Haigland
R		Circular routes for recreational cycling
R		Keep in mind emergency access for all planned facilities
R		Raised crosswalks along Sparks
R		existing alleys (Terrace vs Kitmat)
R		Improved Pedestrian Crossing
R		Improve Lakelse
R		Need Bike/Ped Lanes on Straume
R		Safety for children
R		Bike lane and sidewalk on Kenney South
R		Bike lane and sidewalk on McConnell
R		Put a barricade on Munthe to prevent a left hand turn onto Sparks (only right turn from Hill onto Munthe)
RR		Move CN Switching Yard to west of town - vacant land
S		Keith Avenue needs to have continuous sidewalks (local improvement taxing)
S		Current subdivision bylaw for sidewalks needs to change
S		2 sidewalks on old bridge + Highway 16 bridge would be great, cyclists cannot pass safely
S		Highway 16 bridge - sidewalk is narrow with no barrier between sidewalk and road
S		New pedestrian/bike walkway from George Little House to Keith on Kalum
S		Pedestrian friendly overpass on Kalum + develop co-op
S		Old Bridge is poor for cycling, move light poles to outside of railing
T		Rebuild Howe Creek trail routes to be bike access to Horseshoe Bench
T		Hill routes to Birch Hill bench are poorly designed
T		Riding Cyclists should not be permitted on Pumphouse Trail - erosion
T		Riding Cyclists should not be permitted on top of Lanfear Hill down Hillside going east - erosion
T		Extend Howe Creek trail to connect with Grand Trunk Pathway
T		Need river hiking route
T		Need upgrade to trails in Lanfear Park
T		Trails up to the College - possibility of off-road developments
T		Underpass on Highway 16 bridge
T		No safe pedestrian route on/off Birch Bench
T		3-4 km mountain bike trail to connect Terrace Mountain to Spring Creek Trail
T		Kenney & Howe Creek Trail connection is brutal
T		Howe Creek trail and bench trail connection
T		Wheelchair accessible path to bench
T		Multi-use trail along river to Kitselas
T		Have bridge connect to Kitselas logging road on west side of river

BARRIERS TO ACTIVE TRANSPORTATION IN TERRACE	
RANK	BARRIER
30	Lack of Hwy 16 overpass
28	CN Rail
20	Lack of public education
26	Lack of identification of routes
18	No well marked circular recreational trails
16	Lack of filling in gaps
9	Climate/weather
8	Challenging topography
8	Aesthetic barriers – no development on rivers
8	Lack of regular maintenance
7	Lack of good City planning since 1996
6	Too much traffic (especially in residential areas)
6	Lack of funding
3	Availability of land
3	Lack of bike racks downtown
3	Narrow sidewalks and bridges
2	Excessive speed
2	Perception of safety
2	Winter walking challenges
0	Transition to traffic from paths
0	Location of bike racks, particularly at schools
OPPORTUNITIES FOR ACTIVE TRANSPORTATION IN TERRACE	
RANK	OPPORTUNITY
28	Efficient and safe link from southside to downtown
28	Less steep access to Bench
19	Identify areas to reduce vehicular traffic and increase walking and cycling
18	Comprehensive trail network program
17	Improve visible connectivity
17	Improve old bridge to Apsley
11	Improve signage for on and off-road facilities
15	Underpass on west side of new bridge
11	Improve safety to and from Birch Hill Bench
10	Build loop trail along Skeena – river walk
9	Lakelse closed between Eby and Kalum
9	Access more government funding for cycling infrastructure
4	Bike racks downtown and in more convenient locations
4	Sidewalks on McConnell, Kenney, Lazelle (4900)
3	Traffic calming (near school) on Sparks
0	Outside covered bike racks
0	Sidewalk on Keith between Kenney & overpass on North side

Summary of Other Input

Some input was submitted by email to City staff and to the consultant team by people who could not attend the Open House or other events, or who wished to submit additional comments. A summary of this input is documented below.

INPUT SUBMITTED BY EMAIL/IN WRITING, JULY/AUGUST, 2009:

TRAILS

1. Mandate trails/bikeways/accessible sidewalks (ie. smooth surfaces) in new developments. Trail connections are especially important in cul de sacs.
2. Extend Howe Creek trail to Kalum Lake Drive and Grand Trunk Pathway.
3. Extend Grand Trunk Pathway to Kitsumkalum.
4. Upgrade existing trails between Mountain Vista Park paved trail (at Floyd) and Mtn View School (near NWCC).
5. Improve cycling access to Terrace Mtn trails. Partner with TORCA and public funding sources to add new trails. Possible routes:
 - Munthe/Flathead Jct to top of Back Eddy.
 - High point of Flathead to top of Back Eddy.
 - Reroute Munthe trailhead with switchbacks.

THE BENCH

6. Improving access to the benches is considered a top priority. Suggestion to consider making Lanfear Hill one-way – the hill is deteriorating, sidewalk is unsafe for pedestrians and cyclists also lack facilities.
7. A covered stair walkway up to the bench from foot of Eby St is recommended.
8. A long east-west path from base of Lanfear to top of Kalum Hill suggested, plus a similar path from top of Lanfear to base of Kalum (forming an X).
9. Consider trail to top of Kalum Hill from Howe Creek Spring Hatchery.
10. Idea to put a path along the west side of Lanfear hill, along the slope, meeting up with the Donald St path by Otto's Tree Park.
11. Idea to put trail across slope below Terraceview, or cut off partway down Kalum Hill.
12. Signage: cyclists use sidewalk to go uphill. Drivers slow down/yield to downhill cyclists.
13. Suggestion to widen and sealcoat the existing Lanfear sidewalk.
14. Suggestion to paint curb on Lanfear and Kalum hill sidewalks.
15. Add paved sidewalk/bike lane facilities on:
 - Eby St North to Halliwell.
 - McConnell from Lanfear to NWCC (sidewalk on North side)
16. Bike lanes needed to/from Uplands school.

GENERAL

17. Traffic calming – install traffic circles in residential areas to slow cars, enhance esthetics. This would reduce commuter traffic using residential roads as a short cut. Plantings in the traffic circles could be adopted by neighbourhood groups.

HORSESHOE

18. Lakelse Ave – gravel shoulders need paving between steak house and old bridge. Need a sidewalk on north side from old bridge into downtown. Consider low cost options such as sealcoating or soliciting engineering/asphalt companies to test emerging paving materials as demonstration projects.

19. Park Ave – ideal candidate for east-west bike lanes. Access to Howe Creek/Lanfear via Pheasant. Upgrade path with lights by cedar physio to Park dead end.
20. Eby and Sparks – N-S bike lanes, feeders to downtown from the Horseshoe
21. Maintain “dead ends” for cyclists and pedestrians on Davis and Sparks.
22. Signage needed where bike lanes cross high-traffic streets (eg. Walsh).

SOUTHSIDE

23. Sande overpass may be single greatest missing link for cycling in Terrace. The gravel shoulder on the NW end on the overpass is not safe for riding. There are obstacles such as Hydro poles and tubs; the gravel shoulder is narrow, with a steep bank and no curb cut to crosswalk at Eby.
24. Don't put pedestrian overpass over railyard. Money would be better spent on other projects. Upgrading Sande overpass will be sufficient. Use sidewalks and pedestrian controlled crossings on Keith.
25. Acquire land for riverside trail from Dudley Bridge to west end of Graham. This is a 15+ year old idea that would be an asset for Terrace.

BRIDGES

26. New Dudley Bridge - need a safe walkway/cycling underpass. Rideable ramp up to the highway on the north side would be a wonderful addition. Currently not safe to go under bridge to get to the sidewalk side of the highway. There are two open culvert drains that are a hazard for small children. Gravel shoulder up to highway is loose and steep. This would be a wonderful and simple trail connection. Also, a recommendation to widen the existing sidewalk to better accommodate wheelchairs, bikes and pedestrians; consider gaining space by eliminating the existing 40 cm 'shoulder' on each lane of traffic. Attach wind blocking panels to moderate strong cross winds that are an issue on the bridges. A sidewalk on the south side of the bridge would permit pedestrian access to Ferry Island.
27. Old Skeena Bridge – Several options were put forward: (1) Expand the width of the existing sidewalk. (2) Construct a separate span for pedestrians and cycling at a lower elevation on concrete supports. (3) Consider allowing bikes on the steel grid roadway or retrofit the grid with a path for cyclists. This may require a cyclist controlled light.

GENERAL

28. Ensure sidewalks are in place around designated bus stops.
29. Set up a maintenance plan for regular sweeping (broken glass) and plowing of bike lanes.
30. Enforce parking restrictions so people don't park in bike lanes, or put construction equipment in the bike lanes. Parking on sidewalks also indicated as a problem on Eby and Sparks Streets.
31. Education around protective gear is needed (bike helmets).

Summary of Input from Public Open House #2

EVENT #6:	Public Open House	
LOCATION:	Terrace Sportsplex	
DATE:	Thursday Oct 29, 2009	
TIME:	7:00 – 9:00 PM	
FACILITATION:	LEES + Associates	Erik Lees
	dplConsulting	Danelle Laidlaw
	City of Terrace	Tara Irwin

BACKGROUND

The public consultation process has involved:

1. Interviews with various stakeholder groups
2. Walkability and bikeability tours
3. AT Charrette
4. On-line Survey
5. Open House (2)

The first Open House consisted of mapping of desired improvements, an evaluation of suggested improvements, and the development of 40 recommendations.

The 2nd Open House combined recommendations + on-line survey results to develop implementation preferences.

2ND OPEN HOUSE SUMMARY RESULTS

73% indicated they used active transportation to commute in the winter with approximately the same %age indicating they would walk or cycle more if there was more regular plowing.

Safety is the biggest concern and barrier to active transportation in the Terrace area with 75% of respondents indicating it was their top issue, and 100% putting safety in the top three.

For 31%, weather was the top barrier, and 92% listed weather in the top three.

Other barriers that were brought up were distance, lack of or inadequate facilities (including sidewalks and separated facilities), and hills.

OVERALL TOP PRIORITIES

1. Recreational trail along the Skeena linking Fisherman's Park to the New Bridge
2. Overpass at Kalum Dr
3. Sidewalks on Keith Ave
4. Railings and shoulders on Sande Overpass

PRIORITIES IN EACH THEME AREA

Theme 1 - Schools

10 min “safe” zone around schools

Theme 2 – Bridges & Crossings

Overpass at Kalum Dr

Railings and shoulders on Sande Overpass

Theme 3 – Benches

Trail between Mountain Vista Dr and Floyd

Theme 4 – Downtown

Art theme bike racks

Theme 5 – Southside

Recreational Trail along the Skeena linking Fisherman’s Park to the New Bridge

Sidewalks on Keith Ave

Theme 6 – Horseshoe

Bike to Work Week Challenge

ADDITIONAL COMMENTS

- *Would like more info on proposed additional overpass*
- *Cycle Racks at Farmers Market*
- *Safety Issue – Pedestrians from Kitsumkalum need a safe route to walk to Terrace*
- *Finish Trail as well as improve Kalum Bridge – not safe to cross as a cyclist – no shoulder*
- *I look forward to the prioritized list*
- *The bench roads require improvement so that sidewalks & bicycle use are separated from vehicles. I don’t agree that speed is any greater a problem than other streets.*
- *Well marked connected paths throughout the city*
- *Riverside trails elsewhere are a source of pride – they attract tourists*
- *In my experience and in the research separate cycle routes are safer than on-road routes. I am aware that this is a much more expensive option, but it is my ideal. As it is now, there are many places in Terrace without even marked cycling lanes, and bench access on Kalum & Lanfear are dangerous. On-road riding is very narrow and there are blind corners; yet riding on the sidewalks is both illegal & dangerous to pedestrians.*
- *This type of transportation is good in so many ways – it doesn’t pollute, it is good for your health, it can bring communities together, it should be a priority.*
- *Ensure curb cuts are in place at all pathway ends*
- *If inside rails are put on the existing overpass sidewalk, can a roof to outside wall (enclosed) be created for protection from the wind & rain & snow?*
- *I see 3 main routes for this millennium-like trail through town – One along the river (Fisherman’s Park to old bridge road) then back through town to connect with millennium trail. Then if the Nisga’a Highway to the college and then back through town past Heritage Park and then down the hill to downtown.*
- *At least one bike rack every block*

Appendix B: Terrace Active Transportation Design Guidelines

BICYCLE FACILITY AND PEDESTRIAN TRAIL DESIGN GUIDELINES

Bicycle facilities and trails included:

Dec. 2009

Each condition is illustrated with an example photo, cross section, and plan view, as appropriate.

1. ON-STREET ROUTES

On-street bicycle routes are designed to establish direct and convenient bicycle access to the major destinations within a city, town or regional centre. These guidelines identify minimum width, signage and pavement marking requirements for each of the above-mentioned bicycle route types.

- 1.1 Shared bicycle routes (Shared route)
- 1.2 Marked wide curb lanes
- 1.3 Bicycle lanes
- 1.4 Paved shoulders
- 1.5 Sidewalks



Photo:H.Redman

2. OFF-STREET PATHWAYS

Off-street paths are generally designed to accommodate a range of uses including bicycling, walking and other non-motorized uses. Off-street pathways are most often used in corridors not served by the street system. They can create short-cuts between urban destination points, or provide continuous access along a river, forest or other unique amenity.

- 2.1 Multi use pathway - primary
- 2.2 Multi use pathway - secondary



Photo:H.Redman

3. TRAILS

Trails differ from pathways in that they are not paved or treated and are often steeper. Trails are typically narrow and winding, with natural surfaces, and are used primarily for recreational purposes including mountain biking, hiking or walking. Trails can serve as a complement to on-road cycling routes while forming part of an overall network.

- 3.1 Doubletrack
- 3.2 Singletrack
- 3.3 Equestrian



Photo:E.Lees

4. OTHER DESIGN CONSIDERATIONS

Other design considerations include bicycle parking, clearances, surface materials, grades, signage, pavement markings, bicycle crossing, staircases, illumination, maintenance, traffic calming measures, temporary construction routes, and intersection configuration and laning.

1.1 Signed Bicycle Routes (Shared Route)

User: Bike only

Signed bike routes are simply streets which are designated as bicycle routes. Typically, routes are selected on residential streets which are more attractive than other roads, because of lower traffic volumes and speeds which create a more pleasant cycling environment. Signed bicycle routes are also chosen because they provide expedient routes for cycling. Signed bicycle routes may incorporate different facilities, such as a roadway and a connecting off-road segment.

In many cases, no enhancements are required beyond signage, which makes these routes one of the most cost effective ways of encouraging cycling. However, traffic calming devices should be considered to slow existing traffic or to ensure that motor vehicle traffic is not increased, and where possible, reduced along these routes.

Bicycle Route signs TAC IB-23 signs should be installed at intervals frequent enough to keep cyclists aware of route changes, and to remind motorists of the presence of cyclists. A minimum of 200 m intervals is recommended. In addition, install miniature TAC IB-23 symbols on applicable road name signs (see image). At high volume intersections and locations with reduced visibility, Bicycle Crossing Ahead signs should be installed on the major cross streets.

Appropriate Conditions:

- Local streets
- Posted speed 50 km/h or less
- Low traffic volumes
- With or without on-street parking
- With or without traffic calming
- Parallel to major road corridors

Example: Local streets in grid or redundant street network



Road name sign using miniature TAC IB-23

Photo:H.Redman

Traffic Calming is a combination of mainly physical features that reduce motor vehicle speeds, alter driver behaviour, and improve conditions for all road users including cyclists and pedestrians.

1.2 Marked Wide Curb Lanes

User: Bike only

Wide curb lanes tend to be favoured by experienced cyclists. Wide curb lanes are effective, especially if planned during the construction phase of a project. Often combining Bicycle Route markings with wide curb lanes is the most effective option for bicycle routes. Encouraging use of the wide curb lane requires a combination of education and cycling promotion.

Wide curb lanes should be at least 4.3m wide and no greater than 4.5m wide. It is important to note that this dimension excludes the width of the gutter pan. This means that on a road with a 30 cm gutter, for example, the width of the curb lane measured from the curb face would be 4.6m.

Wide curb lanes are appropriate on arterial and collector roads where on-street parking is provided. The parking width allocated should be 2.5m wide.

Appropriate Conditions:

- Arterial and collector roads with curbs
- Posted speed 50 km/h
- Low to moderate traffic volumes
- Frequent or infrequent turning vehicles
- With or without stopping buses
- With or without on-street parking
- Two-lane collector road with low to moderate volumes



Photo:H.Redman

Example: Arterial road in commercial area with on-street parking

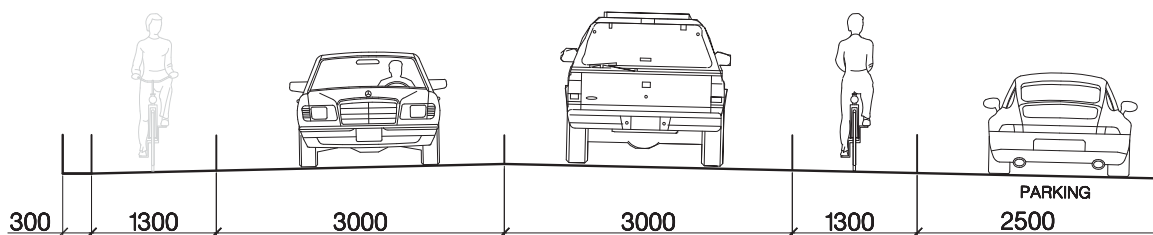

Figure 1.2.1: Typical wide curb lane section

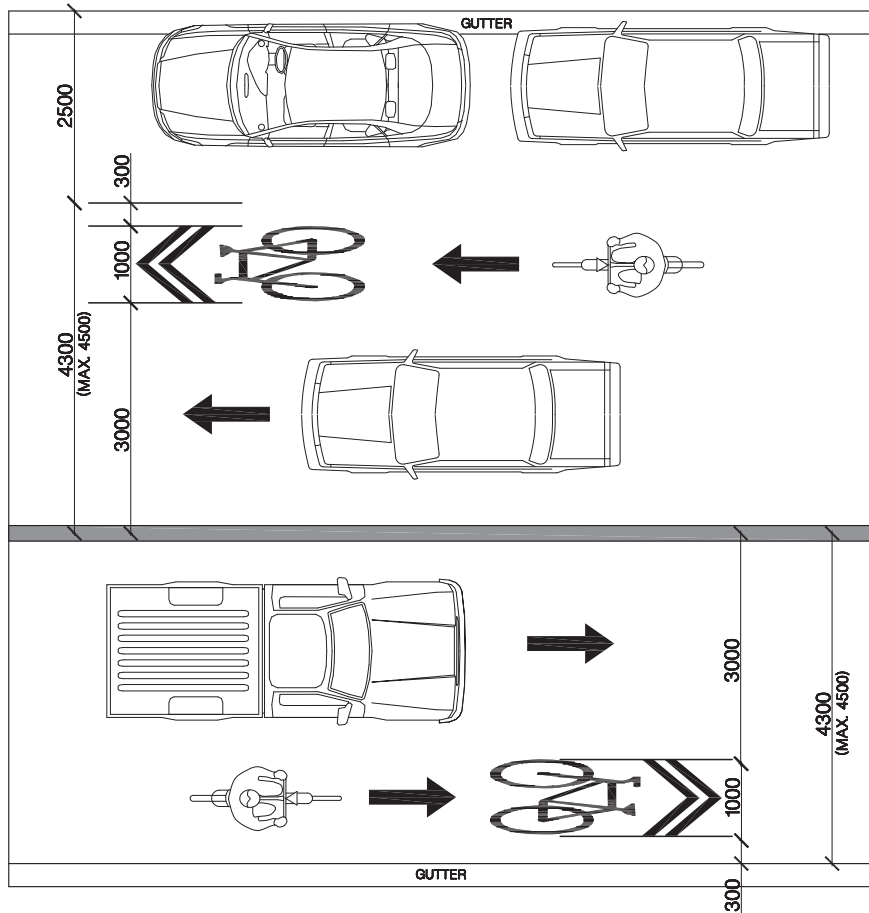

Figure 1.2.2: Typical wide curb lane plan view

The Transportation Association of Canada recommends a wide curb lane pavement marking symbol as illustrated below. Stencils should be located at intervals of no more than 200m, and within 20m in advance of an intersection. Bicycle symbols should only be used where the width of the total lane is a minimum of 4.3m.

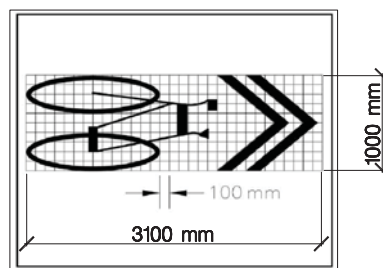

Figure 1.2.3: Wide curb lane pavement marking symbol
Source: Transportation Association of Canada, 1998

1.3 Bicycle Lanes

User: Bike only

Having a designated space on the road for bicycles encourages cycling and promotes a “sharing of the road” attitude amongst cyclists and motorists.

At a minimum, bicycle lanes should be 1.5m in width. Bicycle lanes should not be wider than 1.8m, as this encourages two-way bicycle travel. It is important to note that this dimension excludes the width of the gutter pan.

Bicycle lanes should also be identified with a painted bicycle symbol and an arrow indicating the direction of travel. Bicycle lanes should be marked with a white line, solid between intersections and dashed 20m in advance of an intersection (see diagram in section 4.2 Intersection Configuration and Laning).

Bicycle lanes should be continuous on both sides of the street and should be designated for one-way travel only.

Bicycle lanes should be provided only on roads where most or all of the following conditions are met:

- Urban cross-section (curb and gutter);
- High volume traffic;
- Posted speed limit of 50 km/h or more;
- Low numbers of turning vehicles, and
- Roadways through school zones

On roads with rural cross-sections (no curb and gutter), paved shoulders 1.5m wide should be provided rather than bicycle lanes.

Appropriate Conditions:

- Arterial roads with curbs
- Posted speed 50 km/h or more
- Moderate to high traffic volumes
- Few turning vehicles
- Few stopping buses
- No on-street parking
- Urban highway
- Bridge

Example: Suburban arterial road with access management, bus bays and no parking



Photo:H.Redman

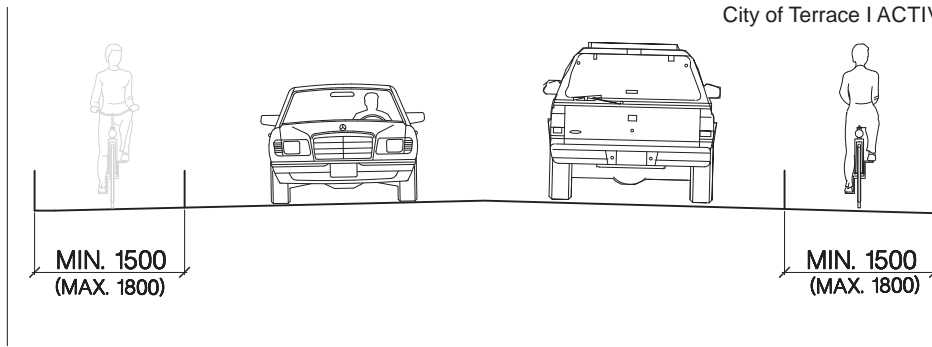

Figure 1.3.1: Typical bicycle lane section

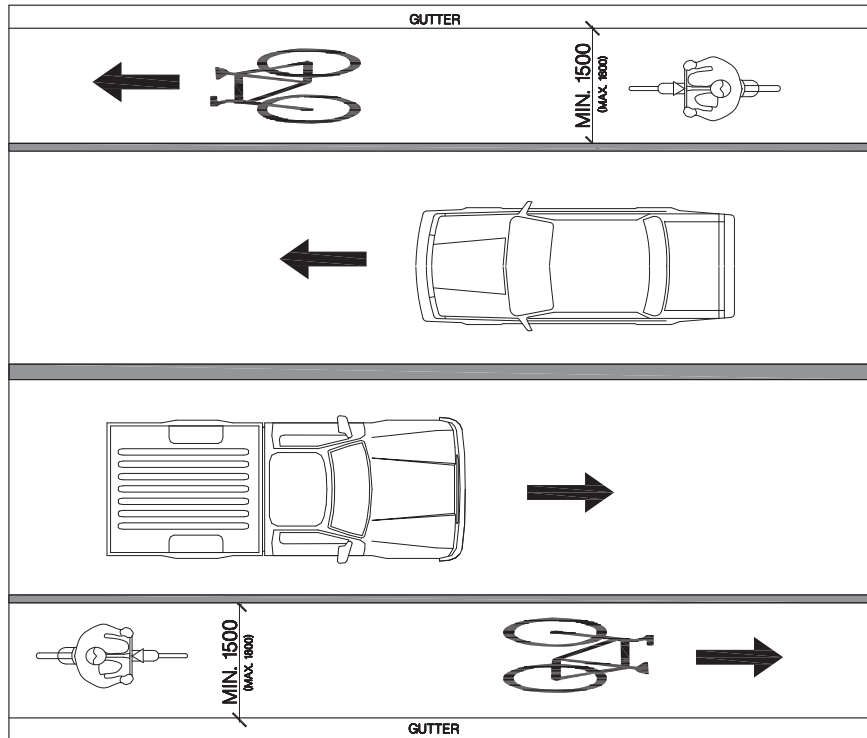

Figure 1.3.2: Typical bicycle lane plan view

All bicycle lanes should be identified with the standard bicycle symbol. This symbol is 1m wide and 2m in length. Stencils should be located at intervals of no more than 200m, and within 20m in advance of any intersection.



Figure 1.3.3: Standard bicycle symbol for bicycle lanes
Source: Transportation Association of Canada, 1998

1.4 Paved Shoulder

User: Bike only

Appropriate Conditions:

- Arterial and collector roads without curbs
- Posted speed 50 km/h or more
- Moderate to high traffic volumes
- With or without stopping buses
- No on-street parking
- Urban arterial road without curbs

Example: Rural highway



Photo:H.Redman

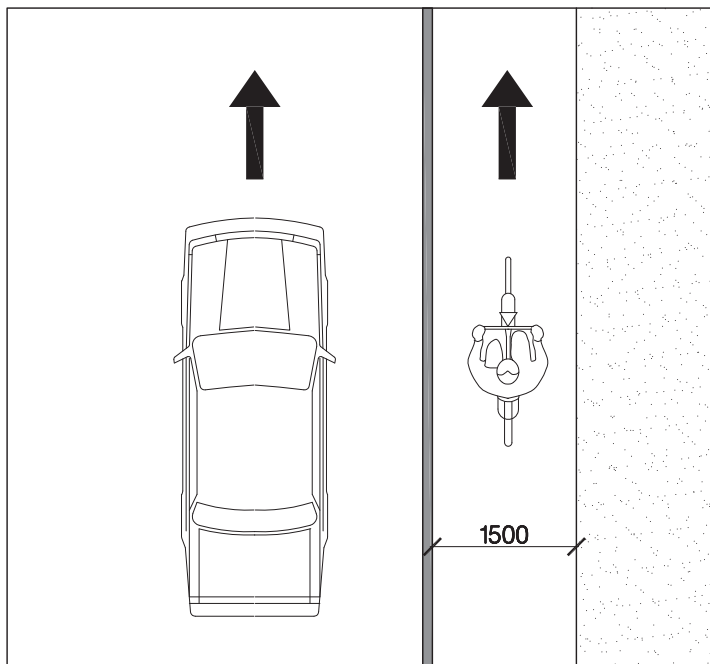
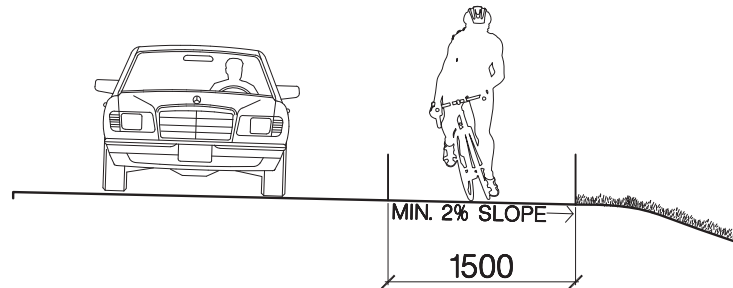

Figure 1.4.1: Typical paved shoulder section and plan view

1.5 Sidewalk

User: Pedestrian only

The use of sidewalks should be encouraged as an alternative to using the automobile to promote a healthier lifestyle. Sidewalks should be safe and universally accessible. It is important that sidewalks provide universal accessibility for the full range of users, including visually and mobility impaired users.

Clearances

Minimum best practice sidewalk width	1.5 m
Preferred width for safe passage of wheelchair and adult	1.8 m
Minimum preferred width for sidewalks adjacent to busy roadways, schools, hospitals, offices and commercial areas.	2.0 m

Figure 1.5.1: Recommended Sidewalk Widths

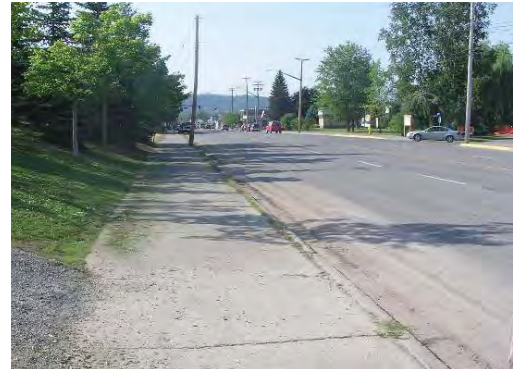

Figure 1.5.2: Typical Terrace sidewalk

Photo: E. Lees

A minimum vertical clearance of 2.0 m is recommended in the pedestrian zone from the sidewalk to potential obstacles such as tree branches, hanging baskets, signs and banners.

Sidewalks in residential areas should be located away from the roadway adjacent to the property line. An offset should be considered to ensure the sidewalk is constructed within the public right-of-way. The offset also allows for a utility corridor. A minimum offset of 0.5 m is recommended. The offset also provides a clearance to private retaining walls, fences, and driveway curbs thereby facilitating municipal sidewalk winter maintenance activities.

Materials

Choose materials that are textured, with a non-slip surface and provide adequate drainage. When forming concrete, minimize joint width (consider requirements of users with strollers, inline skates and also the visually and mobility impaired). Construction practices have a significant impact on the service life of sidewalks. After construction, sidewalks may heave, tilt, crack in various patterns for a variety of reasons.

If best practices are undertaken throughout the life cycle of the sidewalk, the expected lifespan is:

- concrete – 80 years
- interlocking paving stones – 80 years
- asphalt – 40 years

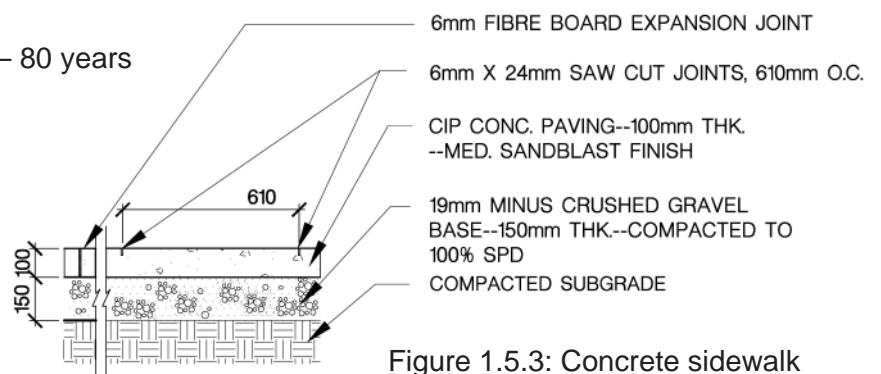

Figure 1.5.3: Concrete sidewalk

A sidewalk set further back from the curb has less potential for damage from vehicles who mount the curb and park on the boulevard. Where the sidewalk is immediately adjacent to the back of the curb, the sidewalk will either be constructed integral with the curb, or have the back of the curb widened below the bottom of the sidewalk to minimize the potential for sidewalk settlement. The front of the sidewalk is then constructed on top of this lip. This design feature helps to minimize differential settlement between the front edge of the sidewalk and the back of curb.

Design Considerations

Sidewalks should be designed to incorporate the requirements for all users. Sidewalk characteristics with a significant impact on accessibility include grade and surface type, and the design and construction of curb ramps.

- Grades and crossfall - In areas where natural grades exceed the maximum grade of 8 percent for persons in a wheelchair, it may not be technically feasible or operationally practical to provide a design solution at the problem location. Consideration should be given to identifying the problem with signage and, possibly providing an alternative route.
- Curb ramps (incl. visual impairments) - Pedestrians with visual impairments receive important navigational information from the sidewalk surface and edges. Several methods are available to assist people with visual impairments at an intersection, including raised tactile surfaces, materials with contrasting sound properties, grooves in the sidewalk, and installation of audible warnings at intersections with signals.
- Surface finish and jointing - To aid accessibility, it is important that the decorative jointing/ scoring is minimized in the pedestrian zone. For concrete surfaces, saw cutting the control/ construction joints and a broom finish is recommended. Any joints in the sidewalk should be as even, level and narrow as possible to facilitate movement of wheeled vehicles, seniors and the visually impaired.
- Trees and landscaping - Trees are a critical element of street infrastructure requirements, and contribute to the green infrastructure. Variables such as soil type, selecting appropriate tree species, growing space and construction practices play a pivotal role in tree root damage to sidewalks. Root barriers installed at the edge of the sidewalk may deflect roots, as may various methods to channel the growth of roots in specific areas, such as structural soil, trenches or pipes filled with soil favourable for root development (Costello and Jones, 2003).
- Winter design considerations - Winter maintenance of sidewalks varies significantly between different municipalities. Some municipalities plow, salt and sand the sidewalks, while others view it as the property owner's responsibility.

Undertaking preventative maintenance is a cost-effective measure to minimize the life-cycle costs for sidewalks. Measures include providing good drainage across the sidewalk and boulevard area, pruning tree roots, and repairing localized defects before they become a larger problem.

(source: Sidewalk Best Practice Guide, 2004)

2.1 Multi Use Pathway - Primary

User: Multi-Use

Multi use pathways are off-street routes, segregated from automobile traffic and with a surface treatment of some kind (typically asphalt, hard packed gravel or crushed limestone). All pathways must be considered as multi use pathways unless a stringent enforcement plan or physical barriers are in place. Multi use pathways will typically attract a range of users including pedestrians, cyclists, runners, in-line skaters, skateboarders, and wheelchair users (depending on the grades). These are most often used as two-way pathways.

Signage indicating a shared pathway is advisable.

Painted centre lines should not be used to separate travel on multi use pathways as conflicts can occur when faster users overtake slower pathway users. On pathways a centre line should be used only on sections where a horizontal curve limits sight distances.

The provincial standard for a bi-directional multi use pathway is 4.0m, however a width of 3.0 m is acceptable for pathways with less than 200 persons per hour during peak periods, and is the recommended width for Terrace. For short sections where there are physical barriers such as trees, boulders, or other objects, a width of 2.4 m is acceptable (see Table 2.1.1). Where the path is adjacent to a roadway, there should be a minimum of 1.0 m separating the path from the edge of the roadway.

The preferred surface material for multi use pathways is asphalt, except in areas where high speeds will be promoted by asphalt or where the natural environment promotes a natural surface. In such areas, hard-packed crusher fines or crushed granite is preferred. Both edges of a paved pathway should be marked with a solid line using reflective white paint to improve visibility during non-daylight hours.

- Tread Surface: crusher fines, crushed granite or asphalt
- Tread Width: 3m
- Cleared Corridor Width: minimum 5m
- Cleared Height: 2.5m
- Gradient Range: Max. 5% (8% over short distances)



Photo: E.Naisby

Design Features: Illumination for night use if appropriate (at trailheads, key intersections, and at intervals along trail where does not disrupt adjacent residential development, incorporate drainage swales, bike baffles at trailheads, 5m buffer when adjacent to residences, universal access throughout, provide benches for resting, large kiosk signage.

	Pavement width for multi use path
Bi-directional Provincial standard	4.0 m
Recommended standard for Terrace	3.0 m
Minimum standard for short sections with physical barriers	2.4 m

Table 2.1.1: Pavement widths for Primary multi use pathway

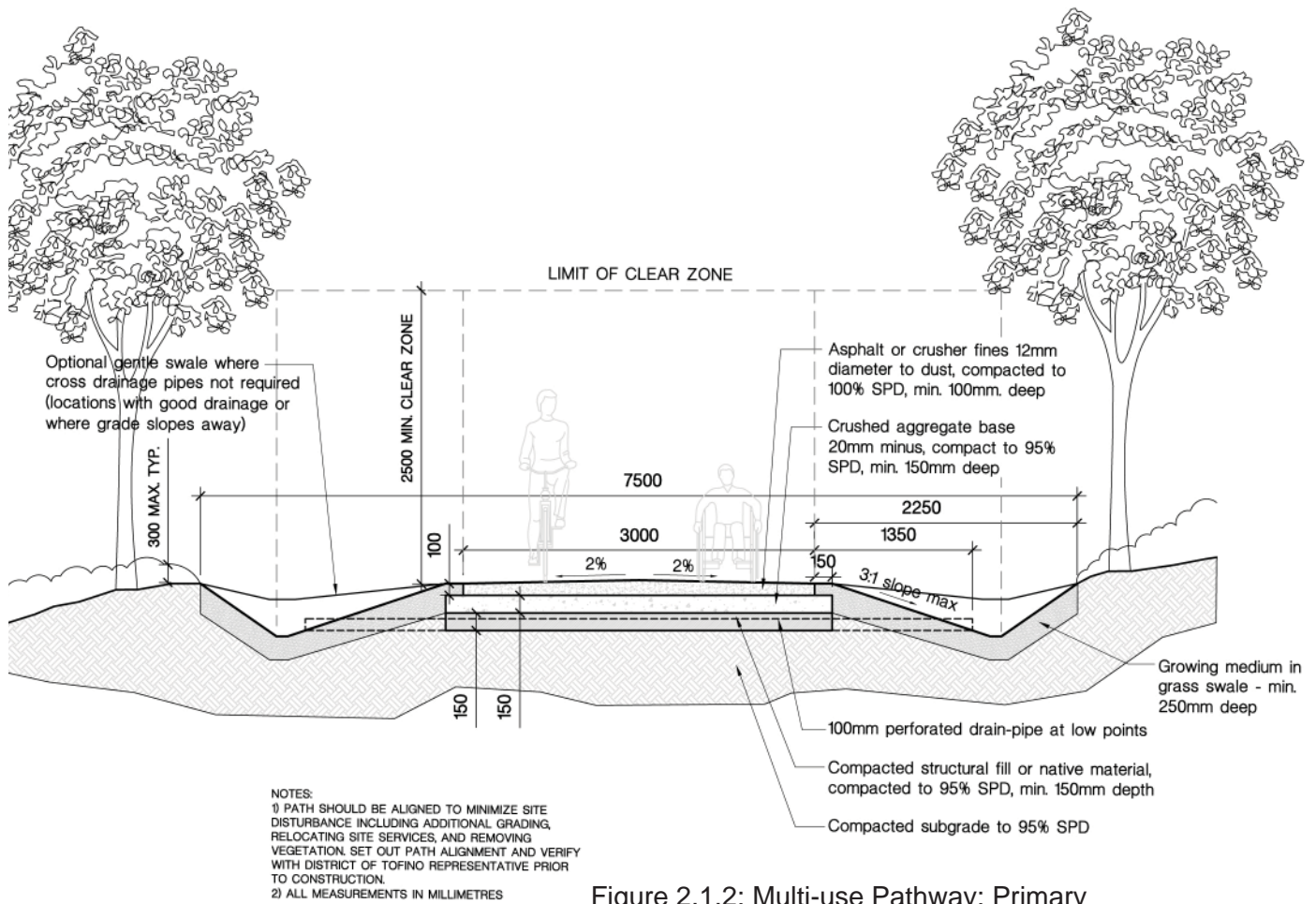

Figure 2.1.2: Multi-use Pathway: Primary

Where a pathway is located close to trees and large shrubs, a 30cm ‘Deep Root’ brand or equivalent root barrier should be placed in the ground between the tree and the sidewalk or path, to prevent roots from heaving and cracking the pathway. Where pavement damage caused by roots on an existing sidewalk exceeds 2 cm in height it is recommended to remove roots, install a root barrier, and repave.

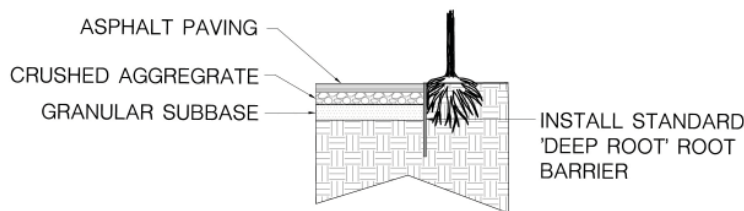

Figure 2.1.3: Root barrier, for multi use path adjacent to trees

2.2 Multi Use Pathway - Secondary

User: Multi-Use

Secondary multi use pathways are similar to primary multi use pathways, except for they are designed for a lesser volume of users and consequently are smaller in scale. There is typically less infrastructure associated with secondary multi use pathways, with less need for illumination and large trail kiosk signage.

- Tread Surface: crusher fines or crushed granite
- Tread Width: 2m
- Cleared Corridor Width: 3.5m
- Cleared Height: 2.5m
- Gradient Range: max. 8% (10% over short distances)

Design Features: incorporate drainage swales, bike baffle at trailheads, provide benches for resting, trail signage.



Photo: E. Naisby

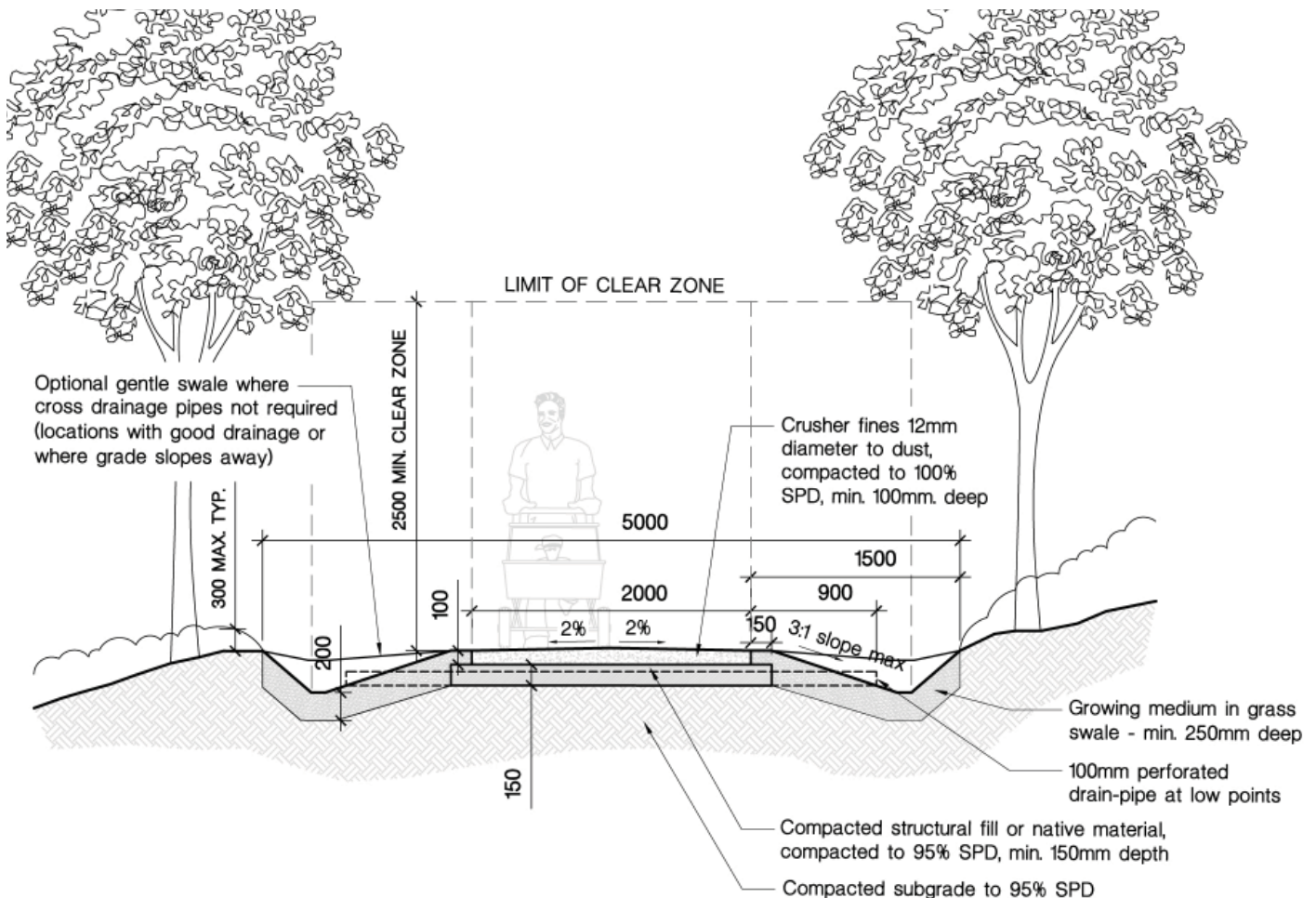

Figure 2.2.1: Multi-use Pathway: Secondary

3.1 Doubletrack Trail

User: Mountain Bike/ Hike

Doubletrack trails are wide enough to accommodate two-way traffic. Typical users are hikers and mountain bikers. The width of the trail also relates to a gentler grade than that found on singletrack trails.

- Tread Surface: native soil, wood chips, stone fines or compacted gravel
- Tread Width: 2-3m
- Cleared Corridor Width: 4m - 5m
- Cleared Height: 2.5m
- Gradient Range: max. 15% (20-25% over short distances)



Photo: LEES+Associates

Design Features: Trail obstacles removed, machine built

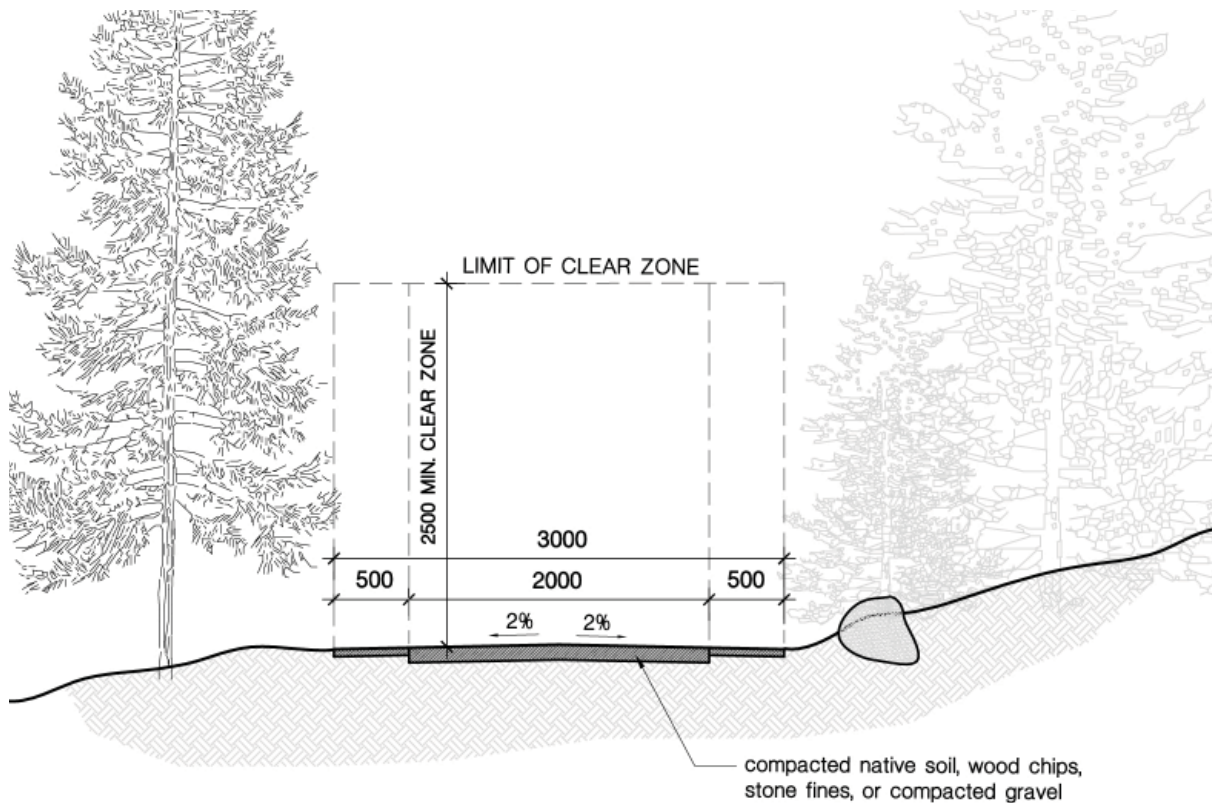

Figure 3.1.1: Double-Track Trail

3.2 Singletrack Trail

User: Mountain Bike/ Hike

Singletrack trails are narrower than doubletrack, attracting a higher level of skill set from its mountain biking and hiking users. The grades are steeper and there are often embedded trail obstacles such as rocks and tree roots.

- Tread Surface: native soil, wood chips, stone fines or compacted gravel
- Tread Width: 30cm-70cm
- Cleared Corridor Width: 1m-3m
- Cleared Height: 2.5m
- Gradient Range: max. 20% (25-30% over short distances)

Design Features: Embedded trail obstacles, machine or hand built, can be rough terrain



Photo: LEES+Associates

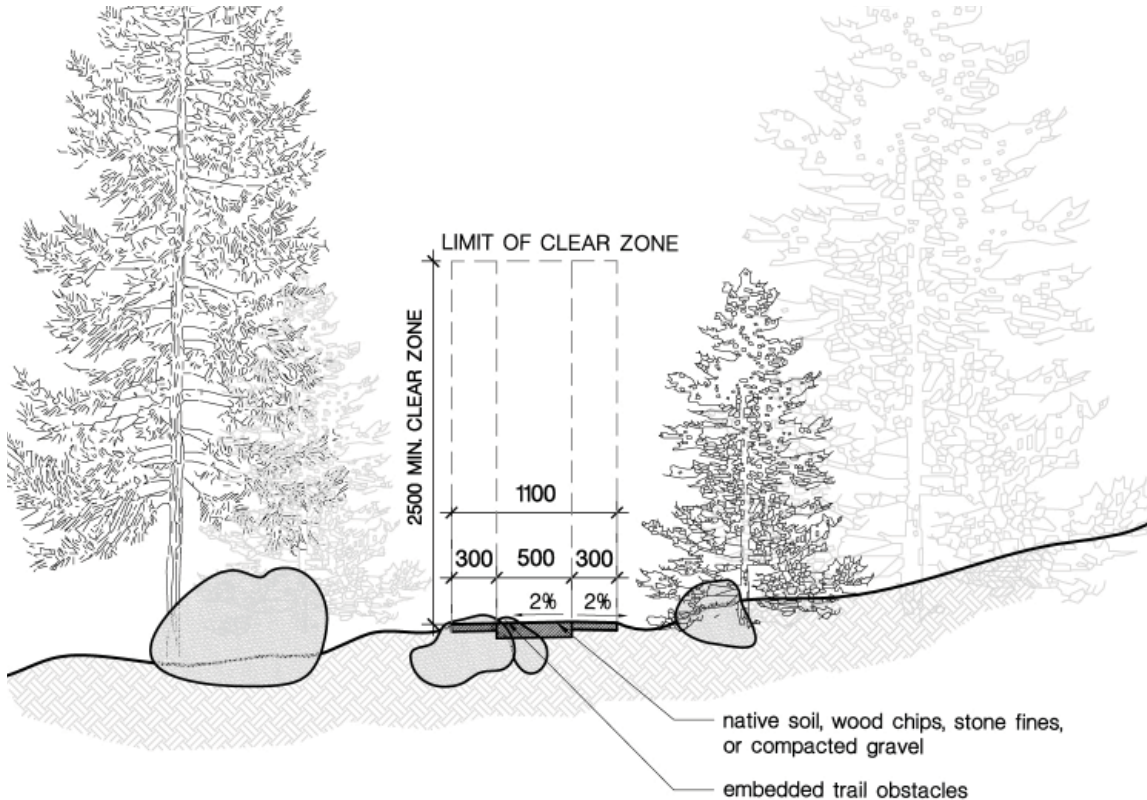

Figure 3.2.1: Single-Track Trail

3.3 Equestrian Trail

User: Equestrian

Equestrian trail standards include a maximum recommended grade for the horse’s ability to climb and down-climb, a surface to the trail that is horse-friendly, and a higher clearance zone to account for the height of the horse and rider. Additional considerations for “backcountry equestrian use” are adequate water sources and rest areas for horses.

- Tread Surface: firm natural materials: hard packed earth, dirt, sand, grass
- Tread Width: min. 1.2m
- Cleared Corridor Width: min. 2.2m
- Cleared Height: 3m
- Gradient Range: max. 25%, incorporate switchbacks to reduce grade

Design Features: avoid swampy areas, rock crevices and large coarse gravel; locate trail away from hazardous materials (eg. barb wire) and sheer cliffs



Photo: www.lcra.org

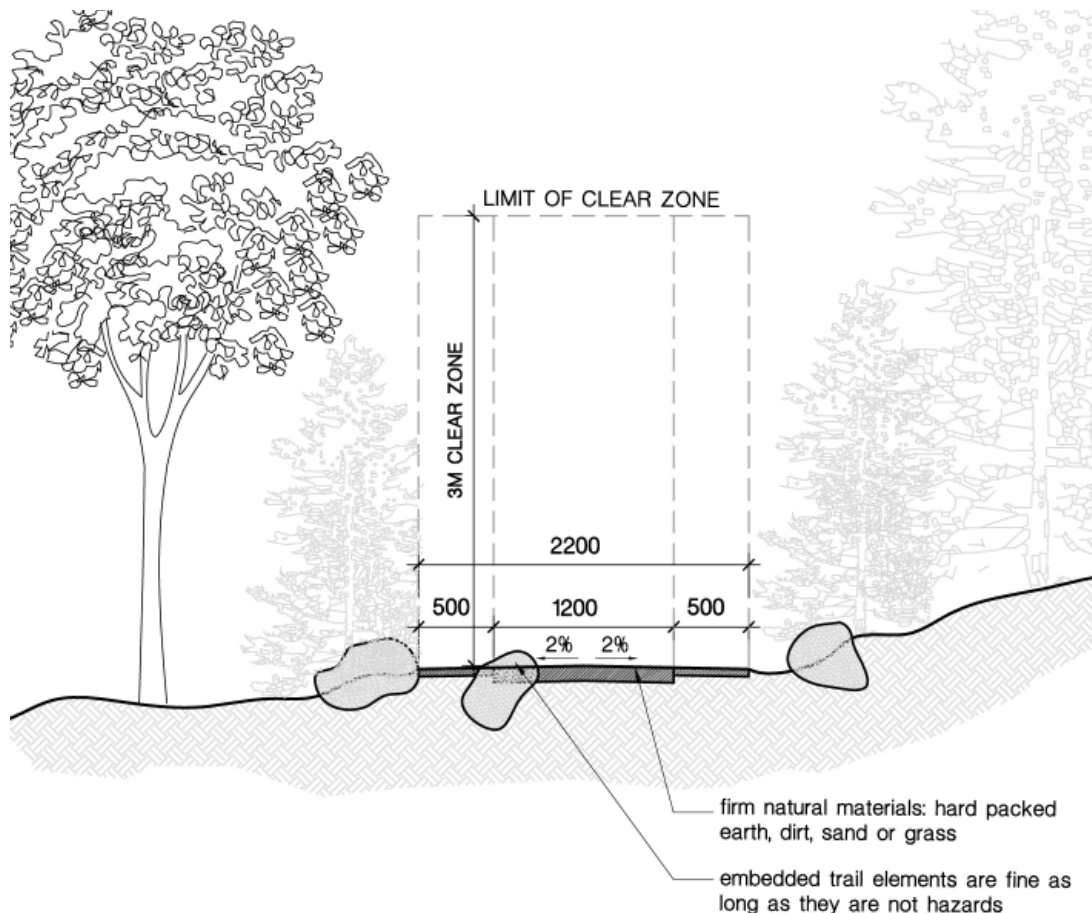

Figure 3.3.1: Equestrian Trail

4. OTHER DESIGN CONSIDERATIONS

Guidelines described in this section include:

- 4.1 Bicycle Parking;
- 4.2 Intersection Configuration and Laning;
- 4.3 Clearances;
- 4.4 Surface Materials;
- 4.5 Grades;
- 4.6 Signage;
- 4.7 Pavement Markings;
- 4.8 Illumination;
- 4.9 Bicycle Crossing;
- 4.10 Temporary Construction Routes;
- 4.11 Maintenance;
- 4.12 Traffic Calming Measures, and
- 4.13 Staircases.

4.1 Bicycle Parking

Bicycle parking is often overlooked. Cyclists need bike parking at the end of their trip, just as motorists need parking lots and other facilities. Bicycle parking may include Class I secure parking (such as bicycle lockers, locked bicycle rooms) and Class II racks.

A bicycle parking stall is defined as a space measuring 1.8m in length by 0.6m in width. Vertical parking should be allowable up to 40% of the total required number of stalls and should be 1.1m in length by 0.6m in width.

- Aisles between parked bicycles should be 1.2m wide.
- Vertical clearance should be a minimum of 1.9m.

Each bicycle stall must be accompanied by a secure bicycle parking device which enables the user to lock the frame and at least one wheel with a “U” style locking device without having to remove a bicycle wheel.

Avoid bicycle racks that support the bicycle by a wheel rather than the frame, or support the bicycle below its centre of gravity. These designs are difficult to use, provide inadequate protection against theft, and are commonly known as “wheel-benders”.

Short Term Parking (Class II)

Short-term facilities are needed in shopping areas or where cyclists will expect parking accessible to and/or visible from their immediate destination. Retail stores, medical clinics, libraries and restaurants are good examples of destinations where short-term bicycle parking facilities can be expected to serve cyclists from a few minutes to an hour or more.

Key elements:

- Convenient access to destination: racks should be no more than 15m (50ft) from the entrance of destinations.
- Parking visible from destination.
- Racks parallel to street and out of pedestrian flow (with sufficient clearance from curb edges and building walls).
- Lighting & personal security.
- Racks positioned to provide 2-sided access.
- Weather protection, if possible. Free-standing or purpose-built shelters will add appeal to any facility, but are secondary to the need for accessibility and security.

Long Term Parking (Class 1)

Long-term parking is needed at workplaces and at multi-unit residential developments. Schools, universities, and some sports, event and/or recreation facilities that require medium to long-term bicycle parking can use a mixture of Class I and Class II parking.

Key elements:

- Ease of access: long-term parking should be no more than 50m (200ft) from building access points. Cyclists will prefer rooms or enclosures that require a minimum number of steps to reach. Facilities that are accessed through a number of doors or through staircases or other constrained spaces are more likely to be ignored. Where stairs are unavoidable, wheel ramps should be provided.
- Lock-ups: secure lock-ups or storage rooms should be located as near as possible to change rooms, showers, workplaces, etc.
- Safety and security: the safety and security of the rider as well as the bicycle are important. Cyclists will be discouraged from cycling if they must use facilities that are poorly lit, distant from access points, or with little other human traffic that can observe comings and goings.
- Signage: signage is useful in directing users to facilities that may be located in parking garages or other locations not clearly visible from the street.

(Source: Adapted from Luton 2005)

Inverted U racks, Post-and-Ring racks and Spiral racks are acceptable, cost-effective bike rack designs.

Some Acceptable Rack Designs:



Photo:H.Redman

Post-and-Ring



Photo:S.Goodridge

U Rack



Photo:S.Braid

Spiral Rack



Photo:D.Laidlaw

Custom bike rack, Central Valley Greenway

Substandard Rack Design:



Photo:H.Redman

Substandard "wheel-bender" bike rack

4.2 Intersection Configuration and Laning

The following are key components to consider for intersections:

- Adequate sight distance is an important element in designing intersections. Consider placement of items such as utility poles, vegetation, shelters and signage poles that may block sightlines between vehicles, cyclists and pedestrians.
- On-street parking should be set back from intersections to allow cyclists adequate sight distance to see oncoming traffic.
- Intersections that meet at 90-degree angles minimize conflicts between roadway users. If possible, avoid taking designated bicycle routes through complicated or skewed intersections.
- For busy intersections, crossing elements and traffic calming devices can help improve safety for cyclists (see sections 4.8 Bicycle Crossings and 4.12 Traffic Calming Measures).
- As a bicycle lane approaches an intersection, dash the bicycle lane lines 20 m in advance to allow motorists to merge.

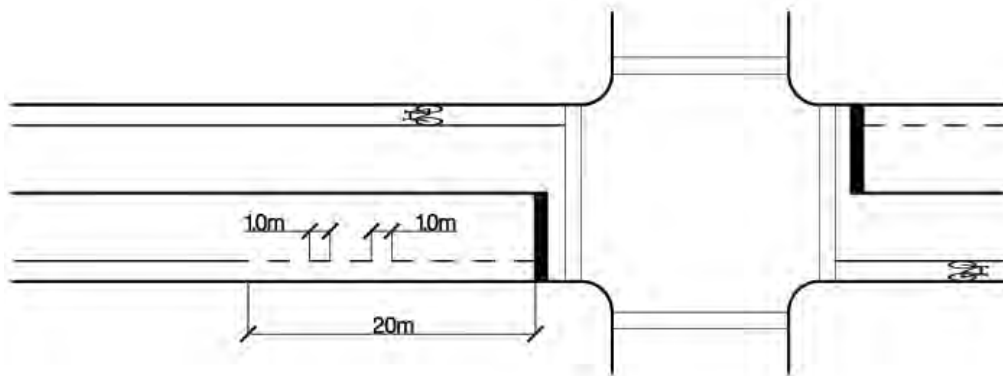

Figure 4.2.1: Typical intersection laning for bicycle

4.3 Clearances

For multi use paths the following clearances should be provided:

- **Lateral clearance** – 0.5 m minimum clearance on both sides of the pathway is recommended. Where fixed objects such as a tree or signpost are adjacent to the path allow 1.0 m clearance to the edge of the pathway.
- **Horizontal clearance** – ensure a clearance of overhead obstructions to 2.4 m.

Generally, a hard-surfacing, such as asphalt or concrete, is preferred for multi use paths in order to accommodate all users including wheelchairs, in-line skaters and others. See asphalt detail in section 2.1 - Multi-use pathway - primary).

Trails in rural settings can be constructed of natural materials that blend with the setting. Unpaved trails are best suited to lower intensity use areas, with more limited uses.

4.5 Grades

If a multi use path is to be an accessible route of travel it should not exceed a grade of 1:20 or 5%. For unpaved surfaces (i.e. gravel), a maximum grade of 3% is recommended. On grades exceeding 5%, additional pathway width of 1 m should be provided and the length should be kept to less than 100m. For longer stretches of 5% + grades, flat plateaus should be incorporated each 100 metres or less.

On a multi use path or road shoulder, a min. 1% - max. 2% cross slope will ensure positive drainage.

Curves control the distance a cyclist can see ahead. The minimum length required to ensure clearance for sight stopping distance can be calculated with an algebraic function. See *Geometric Design Manual*, Urban Supplement, Chapter U.M. Bikeway Design, TAC, 1995 for more information. Where the minimum radius for curves cannot be achieved, the path should be widened to allow cyclists extra room to maneuver.

Class	Universal (for all users)	Intermediate Access (for most users)	Basic Access (for some users)
Max grade (running slope)	1:16 (6%)	1:10 (10%)	1:8 (12%)
Max grade X length before resting area required	1:16 for 15 m	1:16 for 50 m 1:10 for 4 m	1:16 for 100 m 1:10 for 20 m 1:8 for 8 m

Table 4.5.1: Accessible Trails Guideline
 Source: Adapted from Shira Golden (2008)

There are three types of standard bikeway signs recommended for Terrace – warning, guidance and education.

- **Warning signs** advise motorists and cyclists of potential hazards or changes in road way or pathway conditions.
- **Guidance signs** indicate bicycle routes and crossing locations.
- **Education signs** provide information regarding appropriate use of bicycle routes.

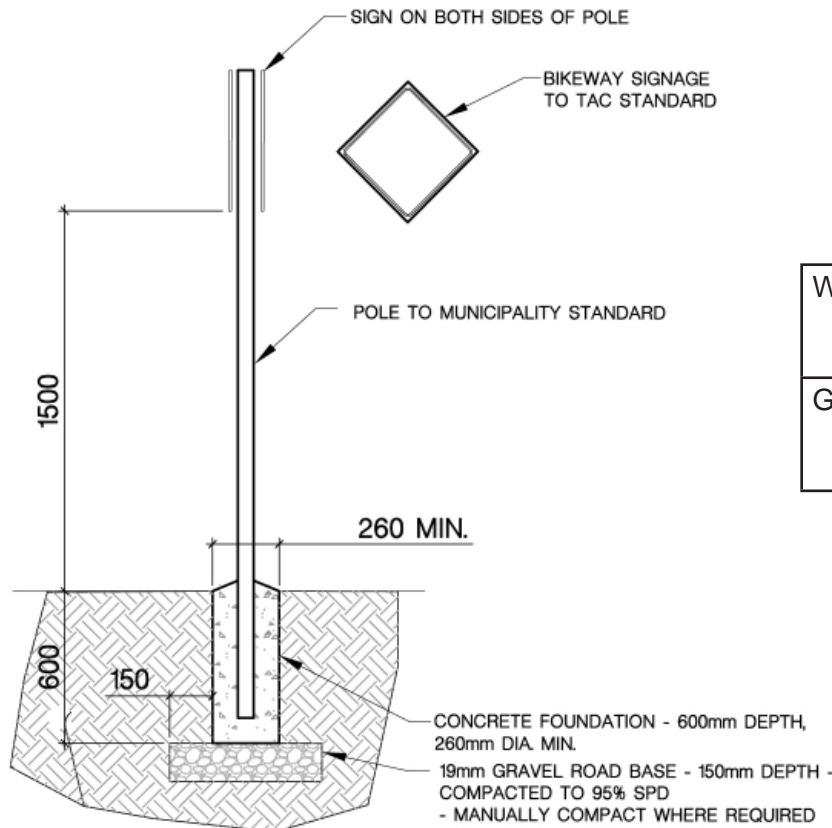

SCALE: 1:30

NOTE: Signage detail for off-street pathways. On-street signage should conform to municipality or MUTCDC standards.

Figure 4.6.1: Typical signage and post section for multi use path

Due to the year-round use of the bicycle routes in Terrace, even during periods of snow, inclement weather, and limited daylight, it is important to have signage in place in addition to the bicycle stencils so that information is discernable when the pavement markings are obscured. See Appendix D for a schedule of signage recommended for Terrace.

In addition to the TAC signs indicated in the Signage Schedule, the City should erect wayfinding signs that indicate distance in kilometers and cycling time to key destinations. This can be calculated using an average cycling speed of 15 km/ hr for bicycle travel. This type of signage can encourage recognition of the bicycle as an efficient means of transportation - it is often surprising how little time it actually takes to get around by bicycle.

Warning Signs	
Guidance Signs	

Figure 4.6.2: Signage types recommended for Terrace

In terms of signage height, off-street pathways signage are generally lower than on-street signage to account for pedestrians' and cyclists' lower line of sight (see Figure 4.6.1). All signs should be placed so they are facing approaching cyclists and pedestrians at right angles. If the sign is reflectorized, angle the sign slightly away from approaching traffic.

Signage used for on-street routes should conform to City standards or as specified in the Manual of Uniform Traffic Control Devices for Canada (MUTCDC).

4.7 Pavement Markings

Symbols and words used on the pavement may be a supplement to signage or used independently to provide information, warning or guidance. All symbols and words should be painted in white, using reflective paint to increase visibility.

Bicycle lane lines are striped with a solid white line, 100mm in width. Standard widths and patterns are provided in the table below.

NAME OF LINE	DIMENSIONS
LANE (SOLID)	
LANE (BROKEN)	

Table 4.7.1: Widths and patterns for pavement markings
 Source: Transportation Association of Canada, 1998

A standard TAC bicycle symbol is used to identify bicycle lanes and wide curb lanes (see section 1.3 Bicycle Lanes). The bicycle symbol is 1m wide and 2m in length, and has been elongated to improve legibility. Stencils should be located at intervals of no more than 200m, and within 20m in advance of any intersection.

4.8 Illumination

In corridors which serve a utility function, such as for commuting to and from work or school or travelling to a commercial centre, or in areas where potential obstacles need to be avoided, lighting should be provided to improve the safety of bicyclists during non-daylight hours. A minimum of 6 lux should be provided, increasing to 20 lux at where a pathway intersects with a roadway.

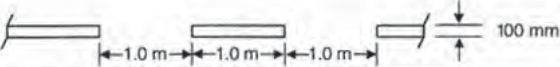
Where bicycles must cross major roads, special crossings are preferred to assist cyclists and others in crossing the road. Possible crossing treatments include:

- **Signed crossing** – signed crossings are used when there is a need to identify the crossing to motorists. On lower volume roadways signage may be all that is required to indicate the presence of bicycles. Crossing signage may be supplemented with pavement markings or with a raised crossing.
- **Median refuge** – if interrupting traffic is not a possibility, a median refuge can be provided to increase the safety of crossing cyclists. The median island allows cyclists to cross one direction of traffic at a time, instead of waiting for gaps in traffic from both directions.



Photo: H.Redman

Raised crossing



Photo: LA Bicycle Coalition

Median refuge

- **Bike Box** - a bike box provides a separate stopping area for bicycles in advance of the stop line for motor vehicles. It allows cyclists to turn left at an intersection where a significant number of motor vehicles travel straight, or turn right. The bike box is a coloured painted area, minimum 4 m deep. A bicycle symbol should be painted in the bike box area. 10 – 20m of bike lane is required in advance of the bike box to provide access to it.



Photo: Transport Canada

Bike Box

Roadway and sidewalk construction projects can disrupt traffic flow and create special hazards for pedestrians and cyclists. The following recommendations should be incorporated into project plans to minimize these problems:

- On highways, enough space should be left at the edge of the construction site to allow a vehicle to pass a cyclist.
- Barricades and pylons can be used to create a temporary passageway for pedestrians. This is particularly important in urban areas. Sidewalk closures should be avoided or minimized as much as possible. Passageway should be wide enough to accommodate a wheel chair, and should have ramps where there are height changes.
- In more urban areas, cyclists may share the lane with lower speed traffic, or a temporary bike lane may be installed. Avoid routing bicycles onto sidewalks or onto unpaved shoulders.
- Construction signs should not obstruct bicycle and pedestrian paths. Where this is unavoidable, do not block more than half the path or sidewalk.
- Bus stops must remain accessible to pedestrians. Where necessary, bus stops may be relocated provided clear and noticeable signs are provided.
- Additional lighting may be required at night to identify hazards.

(Source: Pedestrian and Bicycle Planning 2002)

4.11 Maintenance

Maintenance is an important part of accommodating a cycling network. A lack of maintenance can discourage bicycling and pedestrian activity, and routine maintenance can minimize the City's risk of liability. Below are some types of targeted maintenance activities:

- Establish a maintenance policy and plan – establish written procedures that specify maintenance standards, schedule, quality control, and follow-up that will be used for cycling infrastructure, based on current best practices.
- Repairs – inspect paths and bikeways regularly for surface irregularities, such as potholes and cracks, drainage problems, and damage to signage and lighting. Repair potentially hazardous conditions quickly. Inspect sidewalks for potential root heaving and prune roots or install root barriers before it becomes a problem.
- Establish a citizen reporting system – encourage citizens to report bicycle infrastructure maintenance needs or other problems. Publicize a particular telephone number and e-mail address for submitting information.
- Sweeping – establish a seasonal sweeping schedule. In curbed areas, sweepings should be picked up; on open shoulders, debris can be swept onto gravel shoulders. In the fall, provide extra sweepings to pick up fallen leaves. Put bike routes and bike lanes at the top of the sweeping priority list.

- Vegetation – vegetation may impede sight lines, or roots may break up the travel surface. Vegetation should be cut back to ensure adequate sight lines, and intrusive tree roots may be cut back, or root barriers installed, to keep the pathway surface smooth and level.
- Drainage – malfunctioning drainage systems may cause accumulations of water at bicycle and pedestrian crossings. Drainage grates can pose a hazard if they have openings parallel to the direction of travel, because a bicycle wheel can fall through the slats of the grate. Replace hazardous grates as necessary, or weld metal straps to the grate perpendicular to the direction of travel. Require all new drainage grates to be bicycle-friendly. Collars can be placed on recessed drainage grates to bring them flush with the roadway.
- Pavement to Gutter Transition – on streets with curbs and gutters, 30 – 60cm is typically devoted to the gutter pan where water can drain into catchbasins. In Terrace, many bike lanes have gutter pans where the pavement is not flush with the gutter. Water can further erode the transition making for a rough travel surface for cyclists. To maintain a smooth gutter-to-pavement transition, there should be no more than a 6mm vertical transition. Gutter pans should be inspected during maintenance activities and roadway construction activities

Bike friendly
drainage
grate
example
Photo: H.Redman







Pavement to
gutter transition
on Sparks St.
Photo: H.Redman

- Snow removal – snow and ice can make bicycle travel slow and hazardous. Road plowing should extend into the lane space used by cyclists. Spot salting intersections often creates a hazardous icy patch just past the melted intersection. It is important to schedule sidewalk clearing after roadway clearing. Priority snow plowing should occur around schools, around bus stops and on roadways with bicycle facilities.
- Pavement markings – bikeway markings and symbols may become difficult to see over time, and may wear out faster on higher use routes. It is important that these be inspected regularly and retraced when necessary, especially following pavement overlays.
- Pavement overlays – where new pavement is installed, extend the overlay to the edge of the road or pathway. If this is not possible, ensure that no ridge remains within the bike travel area. Drain grates should be within 6 mm of the pavement height to create a smooth travel surface. Special attention should be given to ensure that utility covers and other road hardware are flush with new pavement. Often, pavement overlay projects offer the opportunity to widen a roadway for cyclists, or to restripe a roadway with a shoulder or bike lane.
- Utility cuts – poorly performed cuts for utilities may leave an interrupted surface for cyclists. Cuts in on- and off-street routes should be back filled with concrete to the surrounding grade to achieve as smooth a result as possible.

(Source: Pedestrian and Bicycle Planning 2002)

Traffic calming features can be incorporated into streets in order to reduce traffic speeds and enhance conditions for non-motorized road users including cyclists and pedestrians. Traffic calming is often associated with existing residential neighbourhoods to address specific problems, but traffic calming features can also be applied to new development areas or to other roads depending on their classification and use. Although traffic calming features are not bicycle infrastructure per se, traffic calming directly benefits cyclists by slowing traffic and increasing the feeling of security among vulnerable road users. Selected traffic calming measures are discussed below with regard to bicycle travel. For more information and specific engineering design standards for traffic calming see the *Canadian Guide to Neighbourhood Traffic Calming*, 1998.

Menu of Traffic Calming Measures and Pedestrian Improvements Appropriate for Terrace	Notes
<p>Curb bulges</p>  <p>Photo: City of Vancouver</p>	<p>Curb extensions can be designed in a variety of ways. When used at an intersection they make the crossing area more prominent and reduce the crossing width for pedestrians. To avoid a “squeeze” as motor vehicles pass cyclists at a curb extension, curb extensions should not extend past the width of the parking lane.</p>
<p>Speed humps</p>  <p>Photo: M.Thoman</p>	<p>Speed humps are wider and smoother than speed bumps and are effective in slowing down motor vehicles as they approach a pedestrian zone. They should be wide enough to slow motor vehicles but still allow bicycles to pass smoothly by. Speed humps are most appropriate on residential streets.</p>
<p>Flashing Beacons</p>  <p>Photo: City of Richmond</p>	<p>Some special crosswalks have pedestrian activated advance warning lights to alert approaching drivers to yield to pedestrians in the crosswalk. These are best used in places where motorists cannot see a traditional sign due to topography or other barriers.</p>
<p>Pedestrian Countdown Signal</p>  <p>Photo: www.walkinginfo.org</p>	<p>Displays a “countdown” of the number of seconds remaining for the pedestrian crossing interval. Increases pedestrian awareness and allows them the flexibility to know when to speed up if the pedestrian phase is about to expire. The signals should be prioritized for areas with pedestrian activity (typically downtowns), roadways with traffic high volumes, multi-lane roadways, and areas with elderly or disabled persons.</p>

<p>Menu of Traffic Calming Measures and Pedestrian Improvements Appropriate for Terrace</p>	<p>Notes</p>
<p>Raised crossings</p>  <p>Photo: H.Redman</p>	<p>Raised crossings are essentially wide speed humps that are marked as crossings. Raised crossings are typically marked with a high visibility crosswalk design. A change in pavement colour or texture (such as paint, coloured concrete, non-slip bricks or unit pavers) on the crossing can also help delineate the pedestrian crossing area and raise motorists' awareness.</p>
<p>Refuge islands</p>  <p>Photo: City of Vancouver, WA</p>	<p>Refuge islands can benefit pedestrians and cyclists by reducing crossing distances and reducing jaywalking. They protect pedestrians and cyclists in cases where there is high volume traffic or confusing flow patterns. Where appropriate, it is important to provide adequate ramping or cuts to accommodate bicycles and wheelchairs.</p>
<p>Curb Ramp</p>  <p>Photo: H.Redman</p>	<p>Curb ramps are sloped ramps that are constructed at the edge of a curb (normally at intersections) as a transition between the sidewalk and a crosswalk. Curb ramps provide easy access between the sidewalk and roadway for people using wheelchairs, strollers, walkers, crutches, handcarts, bicycles, and also for pedestrians with mobility impairments who have trouble stepping up and down high curbs.</p>
<p>Textured Crosswalk</p>  <p>Photo: Urban Review</p>	<p>Textured crosswalks are constructed with the pavers, or can be made of stamped concrete or asphalt. They are appropriate for areas with high volumes of pedestrian traffic and roadways with low visibility and/or narrow travel ways, as in the downtown area of towns and small cities.</p>
<p>Road Diet (Lane Restriction)</p>  <p>Photos: National Complete Streets Coalition</p>	<p>The number of lanes of travel is reduced by widening sidewalks, adding bicycle and parking lanes, and converting parallel parking to angled or perpendicular parking. This is a good traffic calming and pedestrian safety tool, particularly in areas that would benefit from curb extensions but have infrastructure in the way. This measure also improves pedestrian conditions on multi-lane roadways.</p>

Staircases should be designed with a bicycle ramp or wheel gutter down the side or the middle of the staircase so that cyclists can push their bike up and down the stairs. On longer staircases, a gutter on both sides of the staircase will reduce conflict between cyclists going up and down. Wherever possible, the wheel gutter should be a part of the staircase design and not an add-on feature. The wheel gutter trough should be a minimum of 75mm deep by 75mm



Photo: J. Luton

Staircases built with ramp for bicycles



Staircases retrofitted with wheel gutter feature

Accessible Parks and Trails Assessment Toolkit, by Shira Golden, 2008.

Bicycle Parking Best Practices Resource, by John Luton, 2005.

Qualicum Beach Cycling Plan, prepared for the Town of Qualicum Beach by HB Lanarc Consultants Ltd. and Richard Drdul, 2009.

Sidewalk Design, Construction and Maintenance, A Best Practice by the National Guide to Sustainable Municipal Infrastructure, July 2004.

Reducing Infrastructure Damage by Tree Roots - A compendium of Strategies, Costello and Jones, 2003.

Canadian Guide to Neighbourhood Traffic Calming, published by the Transportation Association of Canada (TAC) and the Institute of Transportation Engineers (ITE), Draft April 1998.

Bikeway Traffic Control Guidelines, published by the Transportation Association of Canada (TAC), March 1998. To purchase copies, contact TAC.

The Community Cycling Manual, published by the Canadian Institute of Planners and endorsed by the Canadian Cycling Association and Cycling BC. To purchase copies, contact the Canadian Institute of Planners.

The Technical Handbook of Bikeway Design, published by Vélo Quebec in co-operation with the Quebec Ministry of Transport, the national Capital Commission and the City of Toronto. To purchase copies, contact Vélo Quebec.

The City of Surrey's Bicycle Blueprint. This is one of the most comprehensive bicycle plans developed in North America, and includes considerable information regarding design guidelines and practices. To purchase copies, contact City of Surrey, Engineering Department.

The City of Vancouver's Bicycle Facilities Design Guidelines. These are the first set of comprehensive end-of-trip facility guidelines developed in North America. To purchase copies, contact the City of Vancouver Engineering Department.

Guide for the Development of Bicycle Facilities, American Association of State Highway and Transportation Officials (AASHTO), August 1991.

Cycling Policy, Ministry of Transportation and Highways, September 1996.

Greater Vancouver Regional Bicycle Task Force Policy Recommendations, Strategic Planning Department, GVRD, November 1993.

Langley Master Transportation Plan, City of Langley, May 2004.

Pedestrian and Bicycle Planning; A Guide to Best Practices. By T. Litman, R. Blair, B. Demopoulos, N. Eddy, A. Fritzel, D. Laidlaw, H. Maddox, K. Forster. Victoria Transport Policy Institute. October 2002.

Bicycle Parking (brochure) and other materials available from Cycling BC. Cycling BC maintains an extensive library of literature, video aids, and other materials, including many of the documents identified above.

Appendix C: Best Practice Precedent Studies

BEST PRACTICES IN ACTIVE TRANSPORTATION

Theme 1: Schools

Precedent Study: Walking School Bus

Why develop a walking school bus?

Studies show that fewer children are walking and biking to school, and more children are at risk of becoming overweight. Changing behaviors of children and parents require creative solutions that are safe and fun.

Implementing a walking school bus can be both.

What is a walking school bus?

A walking school bus is a group of children walking to school with one or more adults. If that sounds simple, it is, and that's part of the beauty of the walking school bus. It can be as informal as two families taking turns walking their children to school to as structured as a route with meeting points, a timetable and a regularly rotated schedule of trained volunteers.

A variation on the walking school bus is the bicycle train, in which adults supervise children riding their bikes to school. The flexibility of the walking school bus makes it appealing to communities of all sizes with varying needs.

Parents often cite safety issues as one of the primary reasons they are reluctant to allow their children to walk to school. Providing adult supervision may help reduce those worries for families who live within walking or bicycling distance to school.

Starting simple

When beginning a walking school bus, remember that the program can always grow. It often makes sense to start with a small bus and see how it works. Pick a single neighborhood that has a group of parents and children who are interested. It's like a carpool—without the car—with the added benefits of exercise and visits with friends and neighbors. For an informal bus:

1. Invite families who live nearby to walk.
2. Pick a route and take a test walk.
3. Decide how often the group will walk together.
4. Have fun!



Chester, VT

When picking a route, answer these four questions:

1. **Do you have room to walk?**
Are there sidewalks or paths?
Is there too much traffic?
2. **Is it easy to cross the street?**
3. **Do drivers behave well?**
Do they yield to walkers?
Do they speed?
4. **Does the environment feel safe?**
Are there loose dogs?
Is there criminal activity?



Apex, NC

For more help identifying walkable routes, use the Walkability Checklist that can be found at www.walktoschool.org/buildevent/checklists.cfm.

Reaching more children

Success with a simple walking school bus or a desire to be more inclusive may inspire a community to build a more structured program. This may include more routes, more days of walking and more children. Such programs require coordination, volunteers and potential attention to other issues, such as safety training and liability. The school principal and administration, law enforcement and other community leaders will likely be involved.

► **First, determine the amount of interest in a walking school bus program. Contact potential participants and partners:**

Parents and children	Principal and school officials
Law enforcement officers	Other community leaders

►► **Second, identify the route(s).**

The amount of interest will determine the number of walking routes.
Walk the route(s) without children first.



Mill Valley, CA

►►► **Third, identify a sufficient number of adults to supervise walkers.**

The Centers for Disease Control and Prevention recommend one adult for every six children. If children are age 10 or older, fewer adults may be needed. If children are ages 4 to 6, one adult per three children is recommended.

►►►► **Next, finalize the logistical details.**

Who will participate?

How often will the walking school bus operate? Will the bus operate once a week or every day?

When do children meet the bus? It's important to allow enough time for the slower pace of children, but also to ensure that everyone arrives at school on time.



Sacramento, CA

Where will the bus meet children—at each child's home or at a few meeting spots?

Will the bus operate after school?

What training do volunteers need?

What safety training do children need? See "Walking School Bus: Guidelines for talking to children about pedestrian safety" at <http://www.walkingschoolbus.org/safety.pdf>.

►►►►► **Finally, kick-off the program.**

A good time to begin is during International Walk to School Week on October 3-7, 2005. Walk and look for ways to encourage more children and families to be involved. Have fun!

For more detailed instructions on how to organize a walking school bus, go to:

- ➔ How to Organize a Walking/Cycling School Bus, Go for Green Canada, <http://www.goforgreen.ca/asrts>. Pick "English," then "Tools and Resources."
- ➔ The walking bus: A safe way for children to walk to school, Friends of the Earth UK, <http://www.foe.co.uk/campaigns/transport/resource/parents.html>
- ➔ Walking School Bus - A Guide for Parents and Teachers, VicHealth Australia, <http://www.vichealth.vic.gov.au>. Select "Local Government," then "Walking School Bus." Scroll to bottom to find link to download the guide.
- ➔ KidsWalk-to-School Guide, Centers for Disease Control and Prevention, <http://www.cdc.gov/nccdphp/dnpa/kidswalk/resources.htm>

BEST PRACTICES IN ACTIVE TRANSPORTATION

Theme 2: Bridges and Crossings

Precedent Study: CP Rail Pedestrian/Cyclist Overpass, Port Moody, BC

Description

In November 2005, the City of Port Moody opened a new CP Rail Pedestrian/Cyclist Overpass. The bridge was a result of nine years of planning with partners including the Province of British Columbia, TransLink and several private-sector organizations. The overpass allows pedestrians and cyclists in the growing residential areas better access to schools, commercial businesses, parks and transportation routes. The bridge is almost 175 metres long, with a main span supported by two towers and four cables on each side of the bridge.

Budget

The cost of the overpass was \$1.7 million, which included a 1% allocation for public art.

Partnerships

The funding partners included the City of Port Moody, Polygon Homes, Province of BC, Dalex Developments, Centro Developments, Open Road Auto Group and Translink .

Features

- Width of travel surface: 2.8 metres
- Bridge Length: Has a total length of 119.9 metres made up of 7 spans
- Main span across CPR tracks: 45 metres long
- Slope of structure: Maximum grade of bridge and ramps is 12%

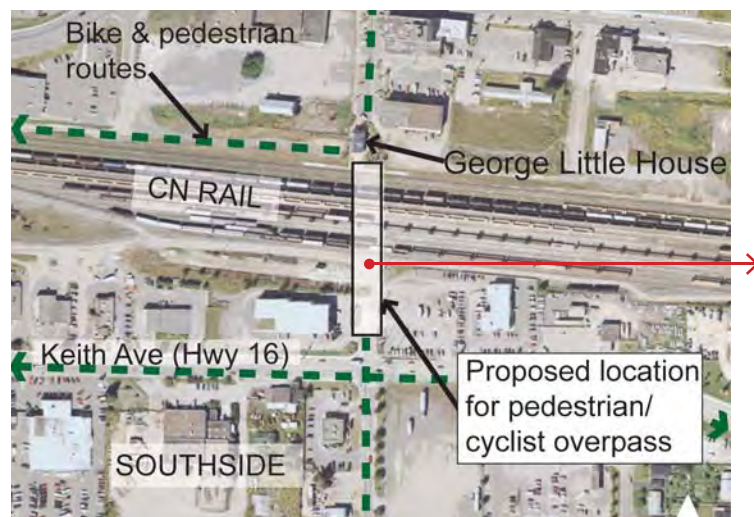

Image: City of Port Moody



Photo: Transport Canada

City of Terrace Priority Project: Kalum Street Pedestrian/Cyclist Overpass



LEES + Associates ♦ dpl CONSULTING

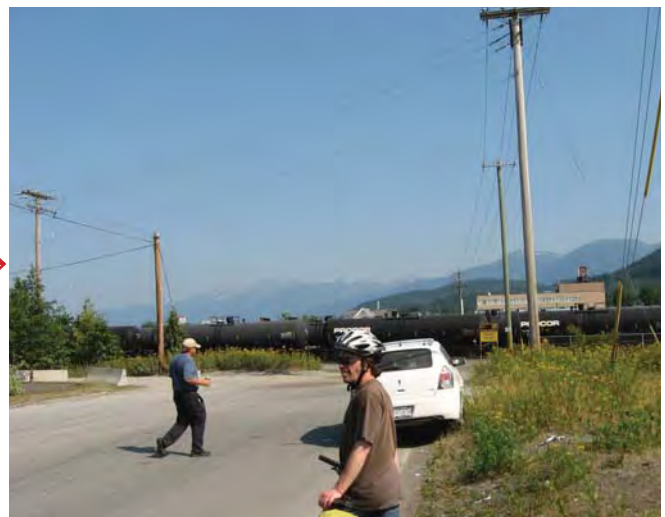

Photo: H.Redman

BEST PRACTICES IN ACTIVE TRANSPORTATION

Theme 3: The Benches

Precedent Study: Mount Royal Staircase, Montreal, Quebec

Description

A wood and steel staircase provides pedestrian access to the summit of Mount Royal. Redesigned in 1995 to replace a concrete staircase, this staircase conforms to the existing topography.



Photo: Thibaut

Precedent Study: Five Finger Rapids Recreation Site, Carmacks, Yukon

Description

A wooden staircase with five landings that serve both as rest areas and viewpoints.



Photo: E.Naisby

City of Terrace Priority Project: Staircase to the Bench



LEES + Associates ♦ dpl CONSULTING

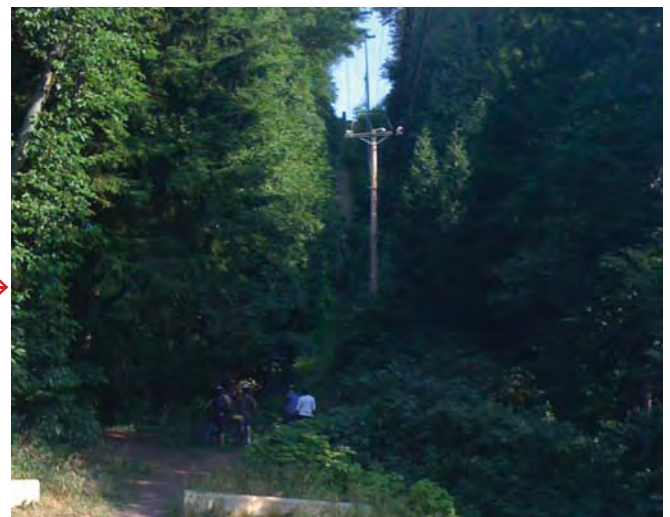

Photo: E.Lees

BEST PRACTICES IN ACTIVE TRANSPORTATION

Theme 4: The Downtown

Precedent Study: Custom Bike Racks, Downtown Whitehorse

Description

The City of Whitehorse has commissioned local artists to design custom bike racks for the downtown core. The new bike racks are both functional and add a unique character to the downtown district.



Photo: H.Redman



Photo: City of Whitehorse



Photo: H.Redman

City of Terrace Priority Project: Install Custom Made Bike Racks in the Downtown



Proposed bike rack locations for the Downtown



Photo:H.Redman

BEST PRACTICES IN ACTIVE TRANSPORTATION

Theme 5: The Southside

Precedent Study: Millennium Trail

Description

The five kilometre Millennium Trail is the first multi-use accessible trail in the Yukon. It loops from downtown core Whitehorse along the scenic Yukon River linking a number of recreational sites along the way including a skatepark, boat launch and a campground. The decision to pave the trail was made after an extensive public consultation process. After initial concern about the urban aesthetic of an asphalt trail along the river, there was eventually consensus to pave the trail in order to provide a “universal access” pathway that would accommodate people with disabilities.

A recent survey suggests that the Millennium Trail is valued by residents as one of the most important recreational amenities in the City. Statistics show that pedestrian passes over the trail’s footbridge average 250,000 per year in a City of 25,000.

Budget

The cost of the trail was \$300,000.

Partnerships

The major funding partners included the City of Whitehorse, the Yukon Electrical Company, Yukon Energy, and the Yukon council on disABILITY.



Photo: H.Redman



Photo: Government of Yukon

City of Terrace Priority Project: Skeena Riverside Recreational Trail



Photo: B.Redman

BEST PRACTICES IN ACTIVE TRANSPORTATION

Theme 6: The Horseshoe

Precedent Study: Bicycle Boulevard

Description

Bicycle boulevards are known by several different names including “local street bikeways” and “bike/walk streets.” They are priority bike streets that provide a continuous, comfortable and attractive place to bicycle. Research indicates that there is a strong preference by cyclists for bicycle boulevards, and suggests that they may be a key tool for attracting new cyclists who are typically less comfortable riding in traffic. These low-speed and low-volume facilities are also pleasant places for pedestrians and other non-motorized users.

Bicycle boulevards tend to work well in grid pattern road networks which are often found near downtown cores and in traditional neighborhoods.

Design elements specific to bike boulevards include:

- traffic calming
- signage and pavement markings
- traffic reduction strategies
- intersection treatments
- prioritization of cyclist travel

The combined impact of these elements is far greater than any single element alone.

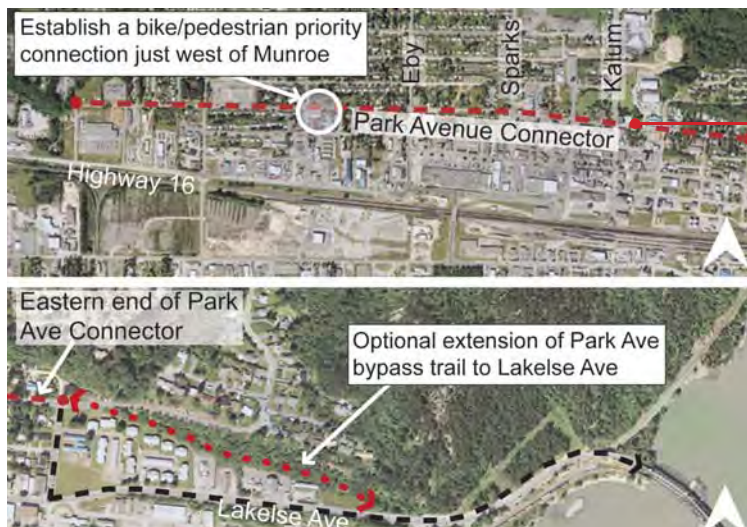

Photo: Bicycle Transportation Alliance



Photo: City of Banff

City of Terrace Priority Project: Park Avenue Connector







LEES + Associates ♦ dpl CONSULTING



Photo: E. Lees

Appendix D: Signage Schedule

TAC SIGN	NOTES	SAMPLE	LOCATION
TAC IB-23 450mm x 450mm	The Bicycle Route Marker sign provides route guidance for cyclists and indicates those roads and pathways which are part of the bicycle system. Place the sign at frequent enough intervals to keep cyclists aware of the changes in route direction, and to remind motorists of the presence of cyclists.		Along all designated bicycle routes at 200m intervals.
Miniature TAC IB-23	Mini Bicycle Route Marker signs make bike routes easily identifiable throughout the City.		On road name signs for all roads designated as bicycle routes.
TAC W11-1 / W16-1	The TAC Share The Road tab is mounted below a W11 series warning sign to create a sign assembly to advise drivers to watch for bicycle travel on the roadway.		On Lanfeard Drive and Skeenaview Drive at 200m intervals
TAC WC-46 / WC-7S 600mm x 600mm	The Pedestrian and Bicycle Crossing Ahead sign indicates to motorists that they are approaching a location where pedestrians and cyclists cross the road.		On both sides of Lanfeard Drive in advance of proposed raised crosswalk (at intersection with Howe Creek Trails).
TAC WC-7S 600mm x 300mm	This "Crossing" tab <i>must</i> be used to support the above sign.		As above.

The TAC signage information above is taken from Bikeway Traffic Control Guidelines for Canada, December 1998. This manual is the recommended source for bikeway signage in Canada, and provides guidance on the design and application of signage and pavement markings for bicycles and bikeways. Copies may be purchased at www.tac-atc.ca.

OTHER	NOTES	SAMPLE	LOCATION
<p>Wayfinding Signs</p>	<p>Wayfinding signs should indicate distance in kilometers and walking and cycling time to key destinations. This can be calculated using an average cycling speed of 15 km/hr for bicycle travel and 5 km/hr for pedestrian travel.</p>	 <p>(visualization)</p>	<p>At key civic and tourist destinations, and along the Grand Trunk Pathway.</p>

Appendix E: Funding Opportunities

Funding through the Development Process

One of the most effective means of funding active transportation infrastructure is to incorporate it into the development process, much as roadways, sewers, parking facilities, parks and other utilities currently are. Specific development related funding strategies include:

- **Developer Incentives and Requirements**

By instituting bylaws which require bicycle parking and other infrastructure, the City can encourage developers to provide active transportation infrastructure through density bonuses, floor space ratio (FSR) exemptions, parking reductions, and other incentives, which often result in higher quality infrastructure.

- **Development Cost Charges (DCC's)**

Development cost charges require developers to pay for a portion of off-site improvements to roads, utilities, and community facilities attributable to their development. The costs of some active transportation infrastructure (including land acquisition costs) can also be recovered through Roads and Open Space DCC's.

- **Payment-in-lieu Funds**

These funds can be used to finance the development of other active transportation infrastructure which might not be required as a direct result of development. For example, a payment-in-lieu can be collected from a developer in exchange for a parking requirement relaxation. This payment can then be used to provide bicycle and walking routes in the adjacent neighbourhood.

Service Clubs

Efforts to accommodate pedestrian and bicycle travel can be co-ordinated with service clubs such as Rotary, Lions Clubs, Kiwanis, etc. which provide labour and/or funding. There are several examples around the province where a service club has provided funding for bicycle lanes and bicycle education programs such as CAN-BIKE. Service clubs are often eligible for grants which the City is not entitled to. By working through the service clubs, additional funds for the Active Transportation Plan can be leveraged from other government agencies.

Donations

One means of soliciting donations is with a bicycle rack program where members of the Business Community, the City and service clubs split the cost of racks.

Volunteers

At times active transportation infrastructure and programs are partially developed and run using community labour and in-kind services. Volunteers have formed bicycle patrols in several communities and form the basis of most Active Transportation Advisory Committees. There are many examples of volunteer-run bicycle education programs. In Terrace, volunteers already participate in trail building and trail maintenance.

Advertising Revenue

Advertising revenue can be used to fund bicycle and walking maps. It is preferable to provide maps free of charge to ensure the widest possible distribution. Advertising can offset the cost of producing the map with production and distribution being covered by the City and the Chamber of Commerce.

Partnerships

Partnerships can be formed with organizations, particularly non-governmental organizations. By forming partnerships with groups such as these, the City may be able to effectively access grants and other funding for programs.

Federal Funding

- Green Municipal Fund

Federation of Canadian Municipalities

The Green Municipal Fund (GMF) is a program that supports municipal initiatives across Canada that benefit the environment, local economies and quality of life through grants and below market loans.

Eligibility: Applicants can request up to \$4 million in loans and \$400,000 in grants for each project. For municipal governments, GMF offers interest rates 1.5 per cent lower than the Government of Canada bond rate for the equivalent term.

- Gas Tax Agreement

The Governments of Canada, British Columbia and the UBCM entered into the Gas Tax Agreement in 2005. The Agreement is focused on achieving three environmental sustainability outcomes: reduced greenhouse gas emissions, cleaner water and cleaner air.

The Agreement includes over \$635 million for BC over a five-year period through three delivery mechanisms: a Community Works Fund, a Strategic Priorities Fund and an Innovations Fund.

Provincial Revenue Sharing

Under the Roads section of the Revenue Share Act, grants are awarded to assist in the development of major municipal roads. Bicycle infrastructure is eligible under this program, and may soon include cost sharing for upgrades to existing routes.

Provincial grant programs

- **Building Canada Fund - Communities Component**
BC Ministry of Transportation

The Canada-British Columbia Building Canada Fund – Communities Component Agreement (BCF-CC) is part of a \$2.2 billion Building Canada Framework Agreement, which will provide communities with support in addressing their infrastructure pressures.

Eligibility: Under the BCF-CC Agreement, the provincial and the federal governments will each allocate \$136 million to support local government infrastructure projects in communities with a population of less than 100,000

people. Eligible projects include public transit, recreation, sport and local roads, among others.

- **The Cycling Infrastructure Partnerships Program (CIPP)**

BC Ministry of Transportation

The CIPP is a cost-shared program where the Government of British Columbia will partner with local governments in the construction of new transportation cycling infrastructure. The goal of the program is to promote transportation cycling (cycling to work, school, or errands) as a means of reducing traffic congestion and green house gas (GHG) emissions.

Eligibility: All British Columbia municipalities and regional districts are eligible to apply for up to \$250,000 in CIPP funding.

- **Infrastructure Planning Grant Program**

Ministry of Community Development

The Infrastructure Planning Grant Program offers grants to local governments for projects related to the development of sustainable community infrastructure. Grants up to \$10,000 are available to help improve or develop long-term comprehensive plans that include, but are not limited to: capital asset management plans, community energy plans, integrated storm water management plans, water master plans and liquid waste management plans.

Eligibility: Grants can be used for a range of activities related to assessing the technical, environmental and/or economic feasibility of municipal infrastructure projects, including transportation infrastructure.

- **LocalMotion**

Ministry of Community Development

The \$40-million LocalMotion program supports projects that promote physical activity, a reduction in car dependency and associated greenhouse gas emissions, as well as increased mobility for seniors and people with disabilities. Projects include vital pedestrian and cycling infrastructure that promote healthier, greener and more accessible communities, from improving sidewalks and creating bike paths to enhancing greenways and increasing accessibility to public amenities.

Eligibility: LocalMotion provides up to 50 per cent of eligible projects costs, with a maximum contribution of \$1 million per year.

- **Towns for Tomorrow**

Ministry of Community Development

Towns for Tomorrow provides up to 75 per cent of project funding for municipalities and regional districts with 5,000 to 15,000 residents, to a maximum contribution of \$375,000.

Eligibility: Projects eligible for Towns for Tomorrow funding include public

transit projects, in addition to recreation, community development and local road projects, among others.

Other Funding

Funding is available from other sources, such as the BC Recreation and Parks Association (BCRPA), related to developing active communities and encouraging physical activity:

- **Active Communities Grants**

The Active Communities Initiative Grant Program is designed to assist communities with the development and implementation of an Active Community Plan, or development and maintenance of walkways, trails and/or bikeways.

Eligibility: Grants of up to \$5,000 are offered twice a year.

Registered Active Communities can apply for either of two grant categories:

- Active Community Plan development or implementation - Apply to develop a community plan or to implement a part of your existing plan. Ideas include launching a pilot project or covering costs for training community members through programs such as HIGH FIVE and Everybody gets to play.
- Walkways, trails and/or bikeways development and maintenance - Examples of eligible projects include hiring a consultant for an environmental assessment or feasibility study for trails or walkways; producing signage or improving the lighting or accessibility and safety of a trail; or developing resources for increasing active transportation in your community.

- **Community Based Awareness Grants**

The Community Based Awareness (CBA) initiative is working to increase awareness of the local opportunities for physical activity and the benefits of active living.

Eligibility: Public Awareness grants of up to \$4,000 are available to communities to support marketing campaigns promoting physical activity using the Marketing Action Plan (M.A.P.) tools and templates.

- **Everybody Active Grants**

BC Recreation and Parks Association (BCRPA) offers \$2,000 seed grants for BC communities to increase physical activity opportunities for people affected by poverty.

Eligibility: Capacity-building and grassroots activities that strengthen the ability of communities to make physical activity possible for all.

- **Walk BC Grants**

Grants designed to assist communities with the development, implementation and/or enhancement of introductory walking programs for inactive adults

(aged 35-54). Grants will be offered once to a maximum of \$5,000.

Eligibility: Preference will be given to applications from communities that have participated in Walk BC training or events.

Tax-Base Funding Sources

Although alternative sources may provide significant funding for pedestrian and bicycle infrastructure and programs, funding from these sources will not be constant nor consistent. Consequently, the City should not rely solely on funding from alternative sources. The City should plan to finance a portion of the Active Transportation Plan through tax-base sources. However, the implementation of larger construction projects outlined in this plan (ie. the pedestrian/cyclist overpass) will require additional funds secured from alternative sources.

For additional federal and provincial funding ideas visit:
www.fraserbasin.bc.ca/programs/tdm_resources.html#cipp

For funding related to community energy refer to a publication of the Community Energy Association: *Funding Your Community Energy and Climate Change Initiatives: A guide to funding and resources for British Columbia local governments.*

